



Whitehall
Manufacturing™

Extremity Whirlpools



E Series 15 Gallon Mobile Whirlpool E-15-M, E-15-MH, E-15-MU

Model E-15-M shown in photo



Product photo/image above may show some available options

Whitehall E-15-M Mobile Whirlpools are recommended for treatment of the foot and ankle area, and when provided with a raised undercarriage, may also be used in treatment of the upper extremities.

Tank Capacity is 15 gallons.

E-15-M, Mobile Whirlpool is recommended for the treatment of the foot and ankle.

E-15-MH, is a Mobile Whirlpool with Handle of heavy duty construction with the hand grip section approximately 36" above ground level for ease in maneuvering the whirlpool from one location to another.

E-15-MU, is a Mobile Whirlpool with Undercarriage of heavy duty construction and fixed height which raises the tank for use in treatment of the upper extremities.

Whirlpool Tank is 25"L x 13"W x 15"D and is seamless welded construction, fabricated from heavy gauge, type 304 stainless steel, polished to a satin finish. Tank rim is reinforced with a concealed stainless steel rod. Tank is fitted with an auxiliary drain valve. Tank bottom is a seamless, rounded covered design to minimize bacteria buildup.

Heavy Duty Swivel Casters support all mobile models. Rear pair of casters are lockable for stabilizing whirlpool during treatment.

Turbine Raising and Lowering Device permits adjustment of desired height and direction of water agitation towards the area of the body to be treated. It is spring balanced and provided with a locking device.

Turbine Assembly functions both as agitator and emptying device. It is equipped with Underwriters Laboratory listed 1/2 HP jet pump motor protected with an ABS plastic shell, and automatic thermal overload protector, and lifetime-sealed bearings. All parts contacting the water are stainless steel, chrome plated brass or bronze.

Thermometer is provided with a dual scale, adjustable calibration, and a stem inserts into a retainer to prevent rattle during whirlpool agitation.

GUIDE SPECIFICATIONS

Provide Whitehall Mobile Whirlpool (specify model number and options) with a 15-gallon capacity, 25"L x 13"W x 15"D. Whirlpool shall be fabricated from heavy gauge, type 304 stainless steel. Construction shall be seamless welded and exposed surfaces shall be polished to satin finish. Tank shall have a reinforced rim and shall be fitted with an auxiliary drain valve. Bottom of tank shall be a seamless, rounded covered design to minimize bacteria build up. Whirlpool shall have heavy duty swivel casters with locking device on rear pair of casters. Provide a turbine assembly with raising and lowering device which functions both as agitator and emptying device, permits adjustment of desired height, direction of water agitation, and can be locked into place. Turbine assembly shall be UL listed 1/2 HP jet pump motor with automatic thermal overload protector, and lifetime-sealed bearings. Provide a thermometer with a stem retainer to prevent rattle when whirlpool is in operation.



Series

- E Extremity Series

Capacity

- 15 Gallons

Type

- M Mobile Whirlpool
- MH Mobile Whirlpool with Handle
- MU Mobile Whirlpool with Undercarriage

Suffix Options (See Whirlpool Option Section for Details)

- ADH Auxiliary Drain Hose Assembly
- AHC1 Adjustable High Chair with Casters
- AHC2 Adjustable High Chair with Rubber Tips
- ALC Adjustable Low Chair
- ALS Adjustable Low Stool
- ARS Arm Rest Support

MODEL NUMBER AND OPTION SELECTIONS

- EG Enviro Glaze Color Powder Coating - Specify Color: _____
(Special Finish Consult Factory)
- GFI Ground Fault Interrupter
- PCS Pump Cover Strainer
- SDP Separate Drain Pump
- WLS Water Level Sensor

Turbine Assembly

Electrical on standard turbine supplied is 115 V 60 Hz
if 220 V is required please specify:

- 50 Hz 60 Hz

- HL Hydro Lift (See Page HL)
Available for E-15-M or E-15-MH

Note: Electrical requirements are 8 Amps / 115 Volts/ 60Hz/ 3 Pole GFI Receptacle.



All dimension figures
in parentheses are in
millimeters.

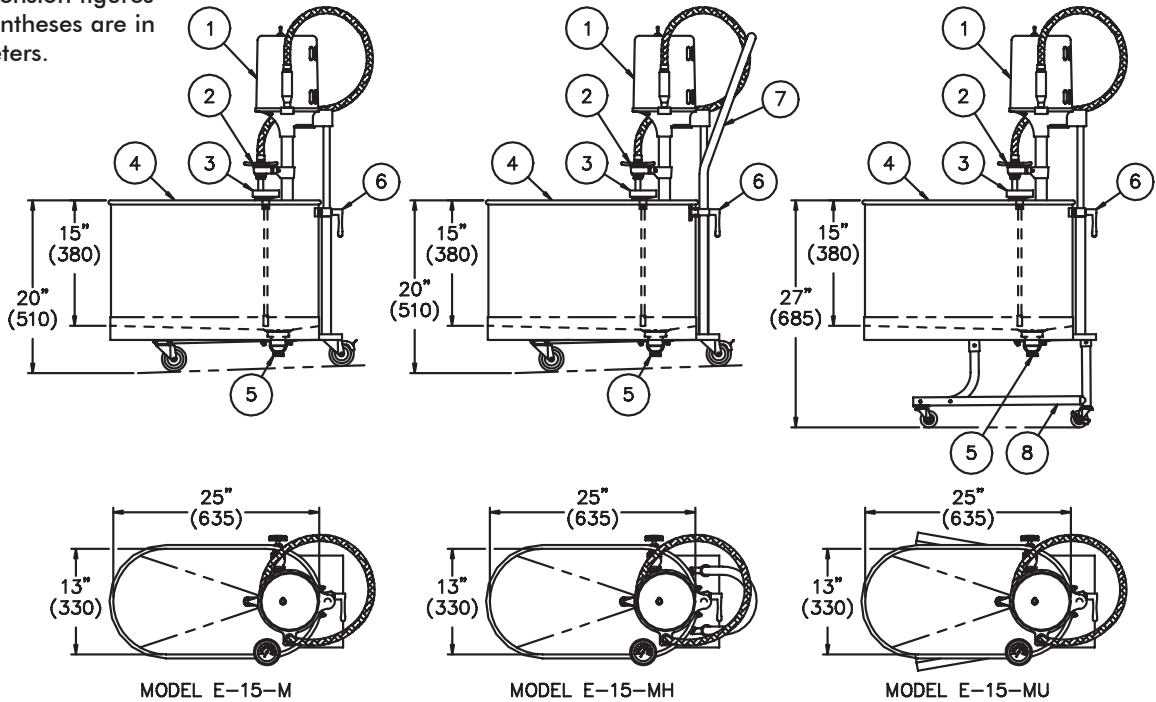

MODEL E-15-M

MODEL E-15-MH

MODEL E-15-MU

MOBILE E-15-M SERIES WHIRLPOOLS

NOTES:

- 1/2 hp Jet Pump Motor
- Variable Pressure Control.
- Thermometer.
- Stainless Steel Tank.
- Auxiliary Drain Valve.
- Turbine Raising & Lowering Device.
- Optional -MH Handle.
- Optional -MU Undercarriage.

All dimensions are nominal and subject to manufacturer's change without notice. Whitehall assumes no responsibility for use of void or suspended data. © 2008 Whitehall Manufacturing, A Division of Acorn Engineering Company. Please visit www.whitehallmfg.com for most current specifications.

SELECTION SUMMARY & APPROVAL FOR MANUFACTURING

Model Number & Options _____ Quantity _____
 Company _____ Date _____
 Contact _____ Title _____
 Approval for Manufacturing/Signature _____