



Whitehall
Manufacturing™

Full Body Immersion Tanks

Use 

F Series 300 Gallon Stationary Full Body Immersion Tank F-300-S



Product photo/image above may show some available options

Whitehall Model F-300-S Full Body Immersion Tank is recommended for debridement of burn patients and others requiring carefully controlled water temperature and/or total immersion hydrotherapy.

Tank Capacity is 300 gallons.

Whirlpool Tank is 89"L x 50"W x 22"D and is seamless welded construction, fabricated from heavy gauge, type 304 stainless steel, polished to a satin inish. Tank bottom is a rounded covered design to minimize bacteria buildup with a reinforced stainless steel base supported by adjustable stainless steel legs. Tank fittings are two 1-1/4" OD overflows, one 1-1/4" NPT filler spout, one lever operated quick open/close drain valve and an adjustable head rest.

Turbine Raising and Lowering Device permits adjustment of desired height and direction of water agitation towards the area of the body to be treated. It is spring balanced and provided with a locking device.

Twin Turbine Assembly functions both as agitator and emptying device. It is equipped with Underwriters Laboratory listed 1/2 HP jet pump motor protected with an ABS plastic shell, and automatic thermal overload protector, and lifetime-sealed bearings. All parts contacting the water are stainless steel, chrome plated brass or bronze.

Thermometer is provided with a dual scale, adjustable calibration, and a stem inserts into a retainer to prevent rattle during whirlpool agitation.

GUIDE SPECIFICATIONS

Provide Whitehall Stationary Full Body Immersion Tank (specify model number and options) with a 300-gallon capacity, 89"L x 50"W x 22"D. Whirlpool shall be fabricated from heavy gauge, type 304 stainless steel. Construction shall be seamless welded and exposed surfaces shall be polished to satin finish. Tank bottom shall be a seamless rounded coved design to minimize bacteria buildup and shall be reinforced with a stainless steel base supported by stainless steel legs which are adjustable. Provide a turbine assembly with raising and lowering device which functions both as agitator and emptying device, permits adjustment of desired height, direction of water agitation, and can be locked into place. Turbine assembly shall be UL listed 1/2 HP jet pump motor with automatic thermal overload protector, and lifetime-sealed bearings. Provide a thermometer with a stem retainer to prevent rattle when whirlpool is in operation. An adjustable head rest assembly is also provided.



Whitehall Manufacturing™

Full Body Immersion Tanks

Series

- -F Full Body Immersion Tank

Capacity

- -300 Gallons

Type

- -S Stationary

Suffix Options (See Whirlpool Option Section for Details)

- -AEH Attachment for Electric Hoist
- -AMF Adjustable Mounting Fixture
- -BH Body Hammock
- -BHS Body Hoist Sling
- -BSS Body Support Stretcher
- -ECR Electric Cord Reel with 25' Cord
- -GFI Ground Fault Interrupter

MODEL NUMBER AND OPTION SELECTIONS

- -MXT3 Thermostatic Mixing Valve (45 G.P.M.)
- -MXT4 Thermostatic Mixing Valve (80 G.P.M.)
- -MXT5 Thermostatic Mixing Valve (125 G.P.M.)
- -MXWH Washout Hose Attachment
- -OEH1 Overhead Electric Hoist (115V 60Hz)
- -OEH2 Overhead Electric Hoist (220V 50Hz)
- -OEH3 Overhead Electric Hoist (220V 60Hz)
- -PCS Pump Cover Strainer
- -PHS1 Patient Handling System (Stretcher Type)
- -PHS2 Patient Handling System (Chair Type)
- -RC Recessed Stainless Steel Cabinet
- -WMB Wall Mounting Brackets

Turbine Assembly

Electrical on standard turbine supplied is 115 V 60 Hz

if 220 V is required please specify:

- 50 Hz
- 60 Hz

Note: Electrical requirements are 8 Amps / 115 Volts/ 60Hz/ 3 Pole GFI Receptacle.

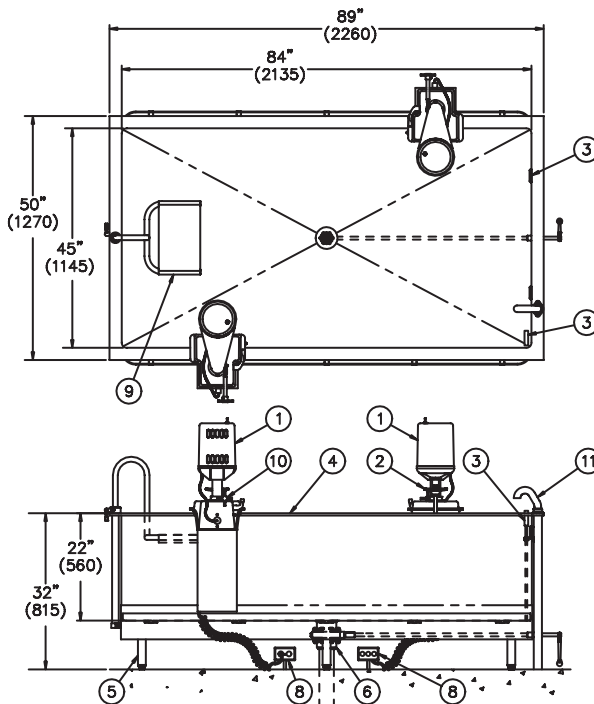

All dimension figures in parentheses are in millimeters.

VALVE	INLETS	OUTLET	DIM A	DIM B	DIM C
MXT3 (45 GPM)	3/4" NPT	1" NPT	10" (255)	17-3/4" (450)	22-1/4" (565)
MXT4 (80 GPM)	1" NPT	1-1/4" NPT	11" (280)	20-1/2" (520)	24-3/4" (630)
MXT5 (125 GPM)	1-1/2" NPT	1-1/2" NPT	12-3/4" (325)	21" (535)	25-1/2" (645)

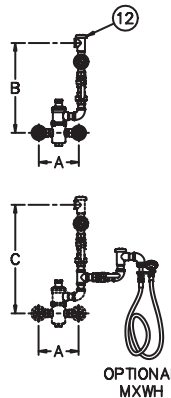

STATIONARY F-300-S IMMERSION TANK

NOTES:

- | | | |
|--------------------------------------|-----------------------------------|---|
| 1. 1/2 hp Jet Pump Motors (2). | 6. 3" Drain Valve Assembly. | 10. Turbine Raising & Lowering Device. |
| 2. Variable Pressure Control. | 7. Overflow Assemblies (2). | 11. Filler Spout w/ 1-1/2" O.D. Tube Assembly. |
| 3. Thermometer. | 8. GFI Receptacles (2) by Others. | 12. Optional Mixing Valve Shown for Reference Only. |
| 4. Stainless Steel Tank. | 9. Adjustable Head Rest Assembly. | |
| 5. Adjustable Supporting Steel Legs. | | |

All dimensions are nominal and subject to manufacturer's change without notice. Whitehall assumes no responsibility for use of void or suspended data. © 2008 Whitehall Manufacturing, A Division of Acorn Engineering Company. Please visit www.whitehallmfg.com for most current specifications.

SELECTION SUMMARY & APPROVAL FOR MANUFACTURING

Model Number & Options _____ Quantity _____
 Company _____ Date _____
 Contact _____ Title _____
 Approval for Manufacturing/Signature _____