

# Patient Handling Systems



PHS2 - Chair



PHS1 - Stretcher



PHS1 - Stretcher



**Whitehall**  
Manufacturing  
A DIVISION OF ACORN ENGINEERING COMPANY

# Specifications

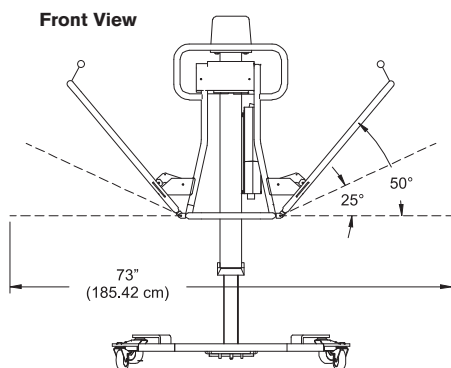
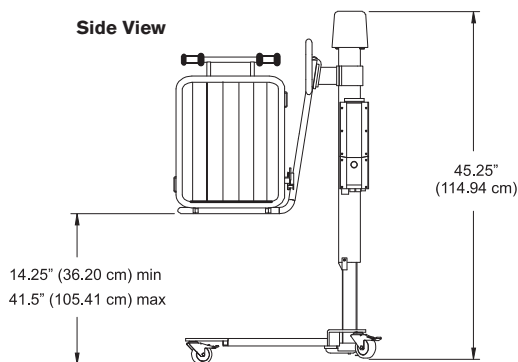

## Model PHS1 Stretcher

Designed for use in Full Body Immersion therapy whirlpools. This stretcher model features a 3-section adjustable stretcher frame made of steel. The back and leg sections are reversible and have five adjustment settings from fully horizontal to seated upright. The stretcher cover allows maximum water circulation during treatment and full support during transport.

Front View

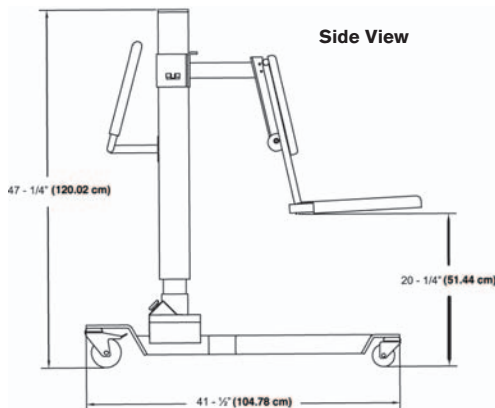
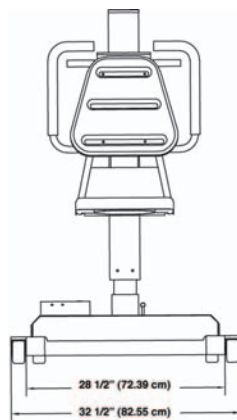

## Model PHS2 Chair

Designed for use with Lo-Boy, Hi-Boy and Full Body Immersion whirlpools where transfer and treatment in a seated position is desired. A steel frame supports the contoured fiberglass seat and backrest. The seat has a safety restraint lap belt, relief holes for drainage, and padded swing away arms that "lock" into position for added comfort and safety.

### Technical specifications for Model PHS1 Stretcher and Model PHS2 Chair

| Mechanical                      |  | Electrical                 |  |
|---------------------------------|--|----------------------------|--|
| Frame                           | Tubular steel, enamel coated.  | Fully Motorized            | 12V DC   |
| Hang Arms & Related Accessories | Stainless steel.   | Battery                    | 12V DC, 7 amp/hour, sealed lead acid. [Battery does not have to be removed to charge.] |
| Lift Drive Mechanism            | Ball screw actuator; battery powered.                                      | Integrated Charging System | Identifies when battery is low and recharging.   |
| Casters                         | One 5" locking, one 5" directional (tracking), and two 3" dual (front).    | Input                      | 120V AC, 60Hz, 4amp, 240V AC   |
| Stretcher/Chair Assembly        | Adjusts 6" to 8" horizontally from mast to accommodate various whirlpools. | Performance                |  |
|                                 |  | Lifting Capacity           | 400 lbs. (180 kg)  |
|                                 |  | Vertical Travel            | 39" (99 cm)  |

## Whitehall's Patient Handling Systems

provide you with a safe and comfortable means to transfer your patients to their hydrotherapy treatment.

Our systems are designed with large directional and locking casters for easy maneuvering.

The heavy duty lift base frame straddles or slides under most hydrotherapy tanks and is easily fitted with a chair or stretcher assembly. The battery operated lift mechanism raises and lowers the patient gently and smoothly, utilizing a hand held push button control unit.



www.whitehallmfg.com

P.O. Box 3527 City of Industry, CA USA 91744  
Ph (626) 968-6681 • (800) 782-7706 • Fax (626) 855-4862