



**Whitehall
 Surgical Scrub sink
 One Station**

Model 4101

Please visit www.whitehallmfg.com
 for most current specifications.



4101-PDM

Fixture May Show Some Available Options

Surgical Scrub Sink is designed for use in health care institutions providing surgeons with a convenient sink for pre-op scrub up.

Fixture is fabricated from heavy gage, type 304 stainless steel and is seamless welded construction polished to a satin finish. The cabinet interior is sound-deadened with a fire-resistant material. The unit is designed to be installed on the wall using a mounting carrier or it can be floor mounted on a stainless steel pedestal base.

Scrub Sink is provided with front panels which are easily removed for access to the water control valve and waste connection. Scrub sink has a sloping bottom surface to minimize splashing and a 1-1/2" OD tailpiece with a 3" flat strainer drain.

Backsplash has a gooseneck spout assembly with a 1-1/2" sprayhead that can be removed for sterilization. Spout outlet does not project directly into flat strainer drain.

T/P Temperature/Pressure Balancing Mixing Valve Control is located on the control panel and maintains a constant water temperature with a flow control of 2.5 GPM. This easily adjustable, anti-scald valve will automatically shut off if the hot or cold water supply fails. Valve is equipped with internal check stops for servicing and to prevent backflow.

Water Supply Valve is a mechanical pilot type, actuated by one depression of a knee-operated front panel and turned off by a second depression. Optional -ETC Electronic Timing Controller or -SO Sensor Operation available in lieu of Knee Operation.

GUIDE SPECIFICATION

Provide Whitehall One Station Surgical Scrub Sink (specify model number and options) 32" wide. Fixture shall be fabricated from heavy gage, type 304 stainless steel, with seamless welded construction polished to a satin finish. Cabinet interior shall have a sound-deadening, fire-resistant material. Cabinet shall also have removable panels to allow access to water control valve, waste connection, stops and strainer. Sink shall have a sloping bottom to minimize splashing, and a 3" flat strainer drain. Gooseneck spout shall have a removable 1-1/2" sprayhead. Fixture shall have a T/P temperature/pressure balancing mixing valve which is easily adjustable at the control panel. Manufacturer shall provide necessary installation instructions.

Please visit www.whitehallmfg.com
 for most current specifications.



Member of
U.S. Green
Building
Council



Recyclable
Product

Complies
with the
following
standards:



UL 1951

CSA C22.2 Nos. 14 & 68



BASE MODEL NUMBER

- 4101 Surgical Scrub Sink (1 Station)

MOUNTING

- MC Mounting Carrier (Off-Floor Installation)
- PB Pedestal Base (On-Floor Installation)

Product Options

- DTD Digital Time Display
- ETC Electronic Timing Controller (In lieu of Knee Operation)
- EFW Eye/Face Wash
NOTE: When specified, ET71-1 Emergency Mixing Valve will be provided
- LFN Laminar Flow Nozzle
- LM Light Module
- PDM Metering Liquid Soap Dispenser
- SFS Soap Flush System
- SO Sensor Operation (In lieu of Knee Operation)
- SS Storage Shelf
- SWV Swivel Nozzle on Gooseneck

Accessories

An appropriate Chronomite Instantaneous Tankless Water Heater may be purchased separately to ship with your scrub sink. Contact your sales rep for details or visit www.chronomite.com

Please visit www.whitehallmfg.com for most current specifications.

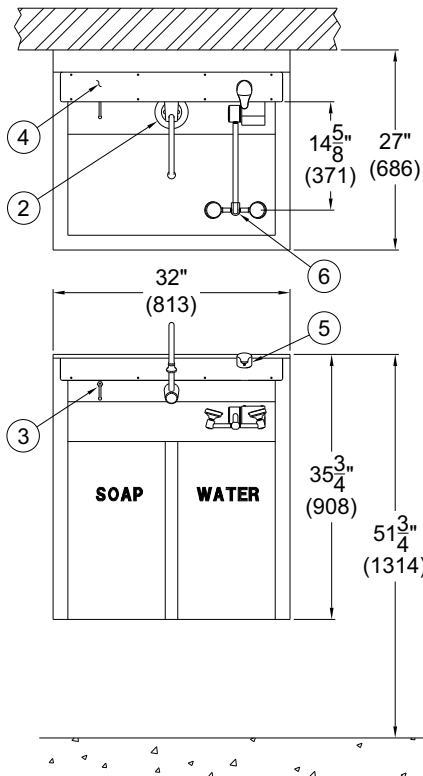

NOTES:

1. Gooseneck Spout Assembly
2. Flat Strainer Drain
3. Optional -PDM Soap Dispenser
4. Control Panel
5. T/P Mixing Valve
6. Optional -EFW Eye/Face Wash

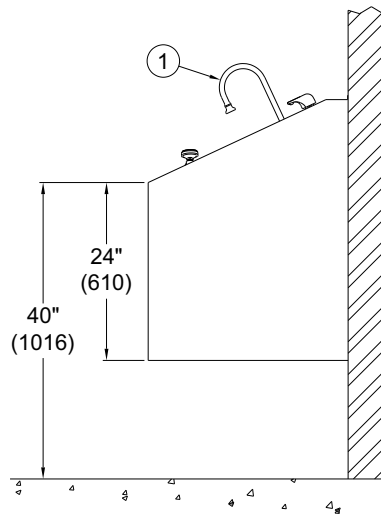

MODEL# 4101-EFW-LFN-PDM

WARNING: Cancer and Reproductive Harm - www.P65Warnings.ca.gov

SELECTION SUMMARY & APPROVAL FOR MANUFACTURING

Model Number & Options _____ Quantity _____
 Company _____ Date _____
 Contact _____ Title _____
 Approval for Manufacturing/Signature _____

All dimensions are nominal and subject to manufacturer's change without notice. Whitehall assumes no responsibility for use of void or suspended data © Whitehall Manufacturing, Member of Morris Group International. Please visit www.whitehallmfg.com for most current specifications.