

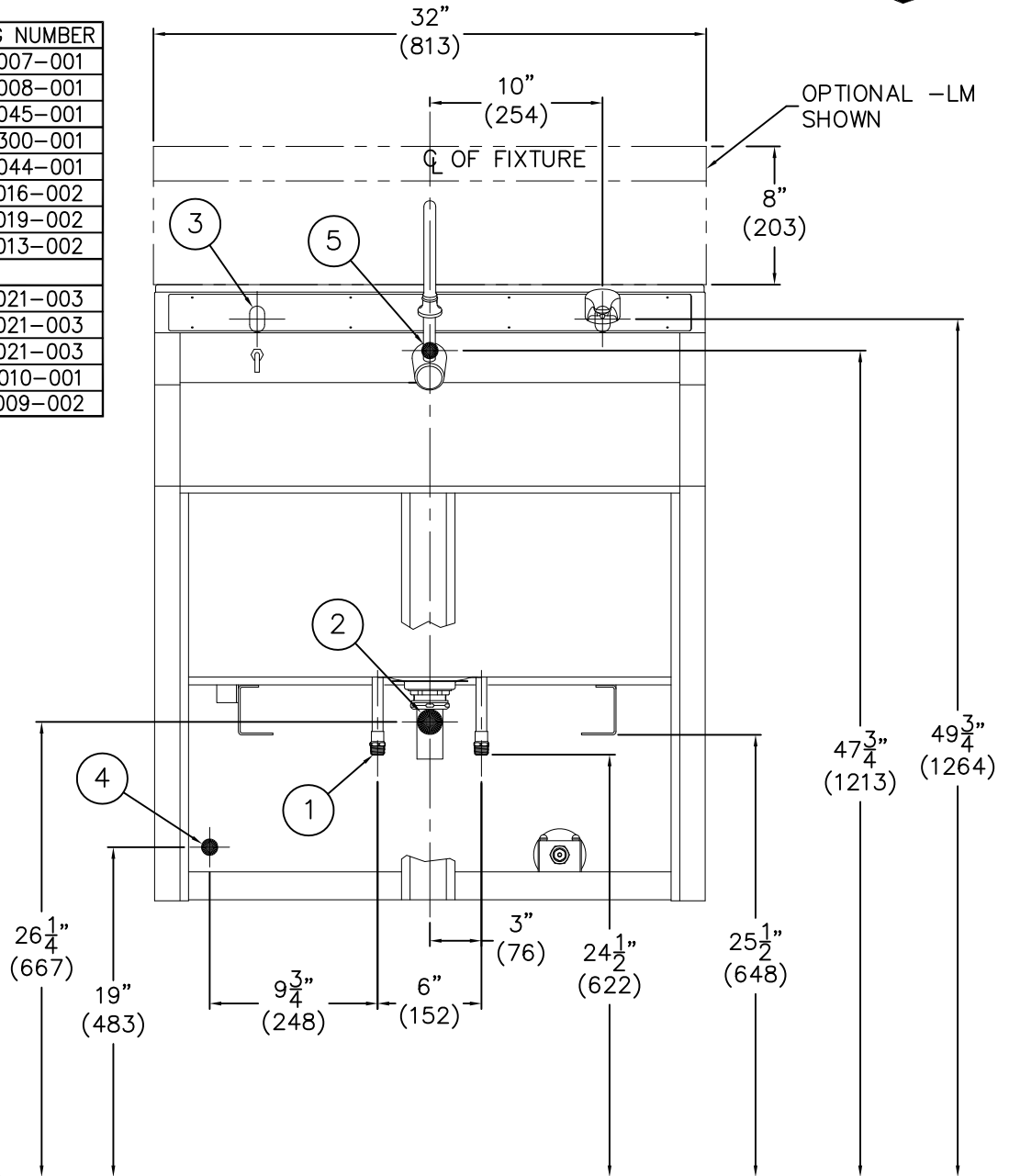

REFERENCE DWG	DRAWING NUMBER
MIXING VALVE	9975-007-001
MIXING VALVE ADJUST	9900-008-001
PILOT VALVE	9975-045-001
SOAP VALVE	9965-300-001
GOOSENECK	9975-044-001
SENSOR/SOLENOID -SO	9955-016-002
WIRING DETAIL -SO	9982-019-002
WIRING / PARTS -DTD	9982-013-002
OPTIONS	
LIGHT MODULE -LM	9930-021-003
ELEC. TIMER -ETC	9930-021-003
DIGITAL TIMER -DTD	9930-021-003
MTG. CARRIER -MC	9930-010-001
PEDESTAL	9930-009-002



INSTALLATION INSTRUCTIONS

A- ROUGH-IN FOR THE FOLLOWING PLUMBING CONNECTIONS:

- SUPPLY INLETS 1/2" NPT (1).
- WASTE OUTLET 1-1/2" O.D. AT WALL (2). DIMENSION SHOWN IS FOR REFERENCE ONLY. P-TRAP IS BY OTHERS.

B- LAYOUT FOR ANCHOR PATTERN AND DRILL:

- (2) 1/2" UNC WALL FASTENERS FOR ANCHORS BY OTHERS (3).

FOR SUFFIX OPTION -ETC: SUPPLY 120V AC, 60 HZ, 3A (MAX) POWER TO FACTORY INSTALLED 24V AC TRANSFORMER WITH JUNCTION BOX. LOCATE ELECTRICAL STUB-OUT (4).

FOR SUFFIX OPTION -LM: SUPPLY 120V AC, 60 HZ TO ELECTRICAL JUNCTION BOX FROM SWITCH BY OTHERS (5).

NOTE: SWITCH SHOULD BE LOCATED NEAR LIGHT MODULE FOR USER ACCESS.

FOR SUFFIX OPTION -DTD: SUPPLY 120V AC, 60 HZ, 3A (MAX) POWER TO FACTORY INSTALLED DUPLEX RECEPTACLE WITH JUNCTION BOX & PLUG-IN 5V DC TRANSFORMER. LOCATE ELECTRICAL STUB-OUT (4).

-SO SENSOR OPERATION: SUPPLY 120V AC, 60 HZ, 3A (MAX) POWER TO FACTORY INSTALLED 24V AC TRANSFORMER WITH JUNCTION BOX. LOCATE ELECTRICAL STUB-OUT (4).

NOTE:

TRANSFORMER(S) MUST BE WIRED TO A GFI PROTECTED CIRCUIT. FIXTURE MUST BE EARTH GROUNDING PER N.E.C. (NATIONAL ELECTRICAL CODE)



ACORN ENGINEERING COMPANY
P.O. BOX 3527 Industry, CA 91744
15125 Proctor Ave Industry, CA 91746
(626) 336-4561 FAX (626) 961-2200

TITLE		
1 PERSON SCRUB SINK ROUGH-INS, * 4101		
MANUFACTURE DATE	DATE ISSUED	DRAWING NUMBER
JANUARY 2012	02/17/12	9930-000-002
TO PRESENT	DATE REVISED	
	08/03/16	

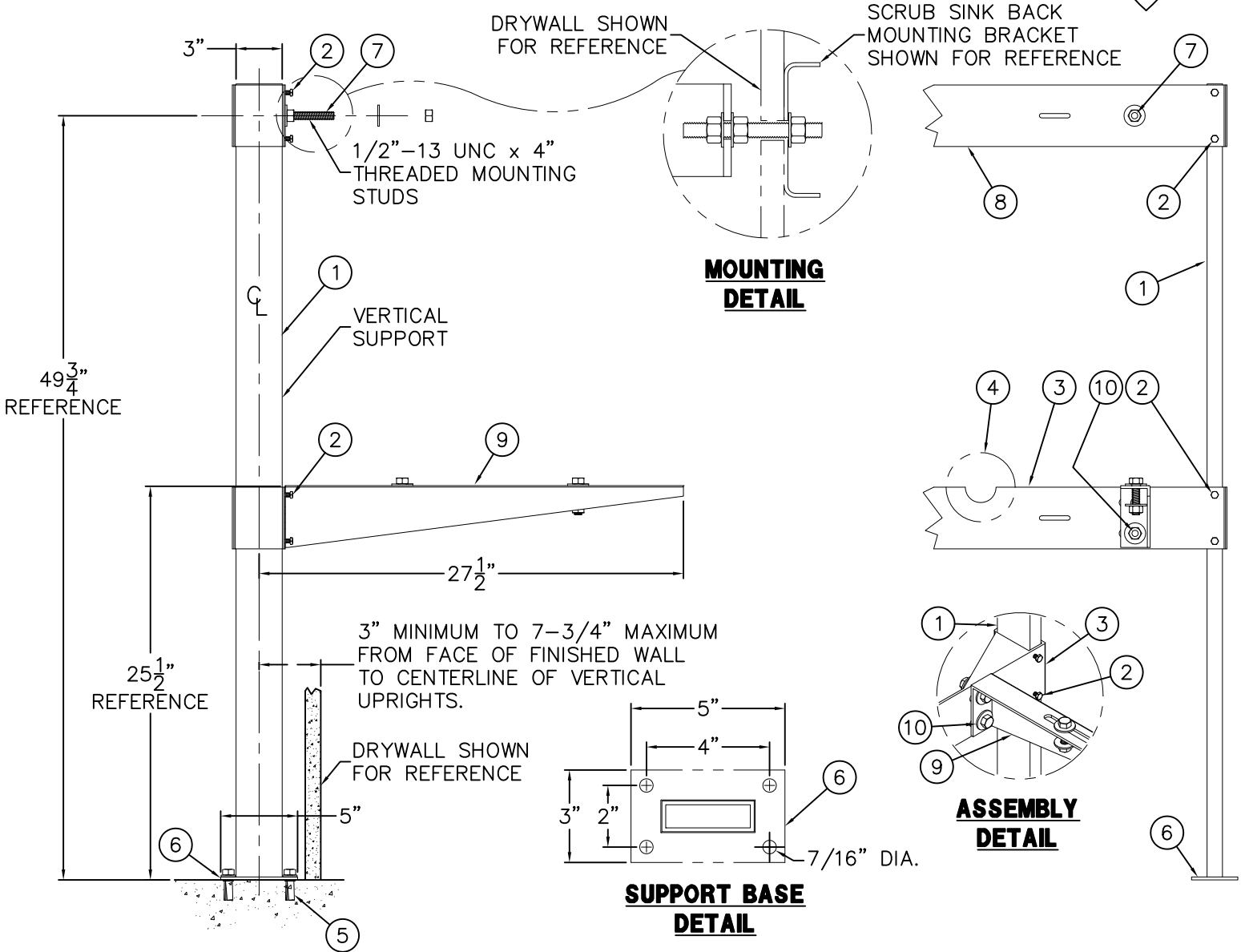

INSTALLATION INSTRUCTIONS:

A- INSTALL HORIZONTAL SUPPORT BRACKETS ONTO VERTICAL UPRIGHTS (1) TO OBTAIN PROPER VERTICAL SPACING USING 1/4-20 UNC x 1/2" BOLTS (2) PROVIDED. NOTE: LOWER HORIZONTAL SUPPORT BRACKET (3) MUST BE POSITIONED SO THAT THE HALF CIRCLE (4) IS FACING UP OR OPEN FOR WASTE OUTLET CLEARANCE.

NOTE: FLOOR ANCHORS AND FLOOR ANCHORING HARDWARE (5) ARE BY OTHERS.

B- ANCHOR SUPPORT BASES (6) TO A RIGID FLOOR OR OTHER RIGID SUBSTRUCTURE WITH INSTALLER PROVIDED HARDWARE (5). SEE DETAIL.

C- INSTALL 1/2"-13 UNC x 4" THREADED MOUNTING STUDS (7) NUTS AND WASHERS ONTO UPPER HORIZONTAL SUPPORT BRACKET (8).

D- INSTALL CARRIER ARMS (9) ONTO LOWER HORIZONTAL SUPPORT BRACKET (3) AT DIMENSIONS SHOWN WITH 1/2"-13 UNC x 1-1/4" BOLTS (10) NUTS AND WASHERS PROVIDED.

E- CHECK CENTERLINE DIMENSIONS ON SCRUB SINK. ADJUST HORIZONTAL LOCATIONS AS REQUIRED.

F- ALIGN AND POSITION SCRUB SINK ONTO CARRIER ARMS (9) AND MOUNTING STUDS (7). SECURE WITH REMAINING HARDWARE TO COMPLETE INSTALLATION.

SEE APPLICABLE DRAWING FOR FURTHER DETAILS.
 4101 1-STATION SCRUB SINK 9930-011-001
 4102 2-STATION SCRUB SINK 9930-012-001
 4103 3-STATION SCRUB SINK 9930-013-001

 WHITEHALL MANUFACTURING P.O. BOX 3527 Industry, CA 91744 15125 Proctor Ave Industry, CA 91746 (626) 968-6681 FAX (626) 855-4862	TITLE TYPICAL CARRIER INSTALLATION FOR SUFFIX OPTION -MC		
	MANUFACTURE DATE APRIL 1992 TO PRESENT	DATE ISSUED 04/30/92	DRAWING NUMBER 9930-010-001
		DATE REVISED 06/20/12	

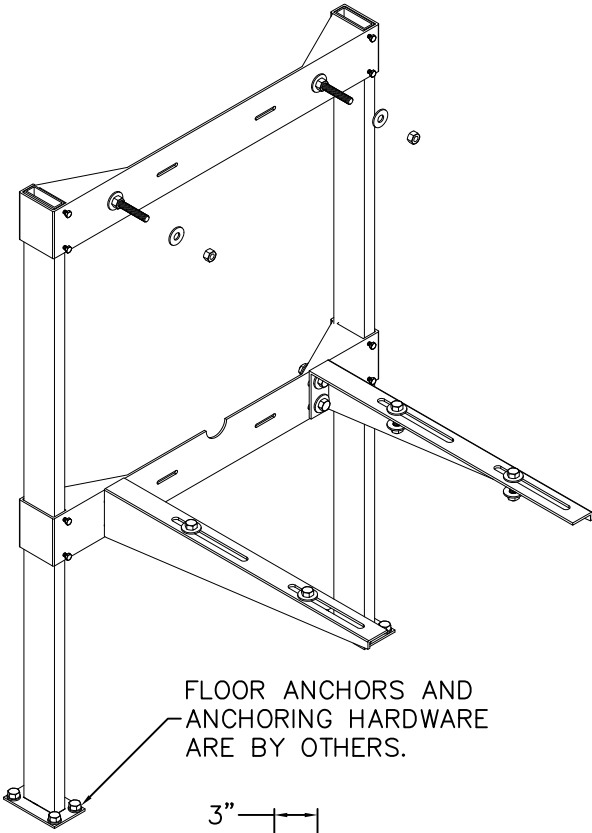

FLOOR ANCHORS AND ANCHORING HARDWARE ARE BY OTHERS.

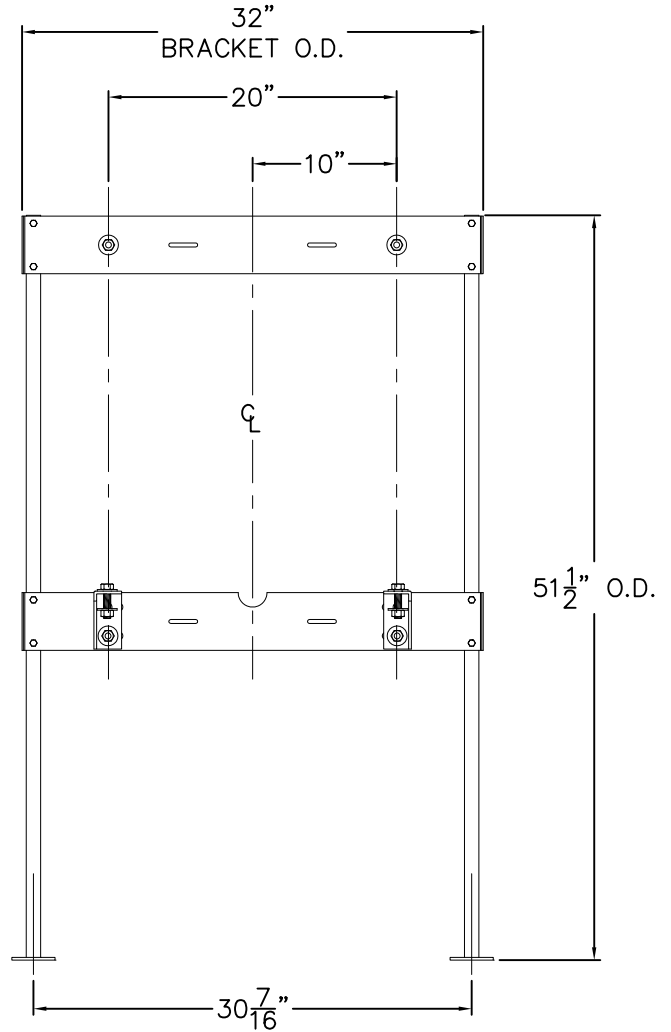
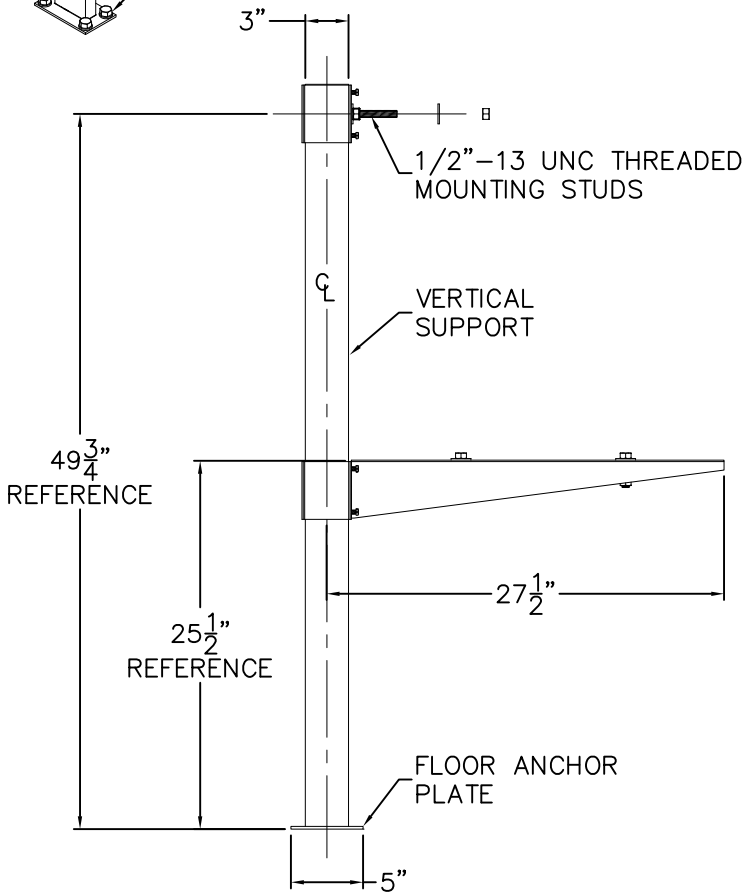

WHITEHALL MANUFACTURING
 P.O. BOX 3527 Industry, CA 91744
 15125 Proctor Ave Industry, CA 91746
 (626) 968-6681 FAX (626) 855-4862

TITLE 1 STATION SCRUB SINK CARRIER PHYSICAL DIMENSIONS		
MANUFACTURE DATE JANUARY 1990 TO PRESENT	DATE ISSUED 01/01/90	DRAWING NUMBER 9930-011-001
	DATE REVISED 06/20/12	

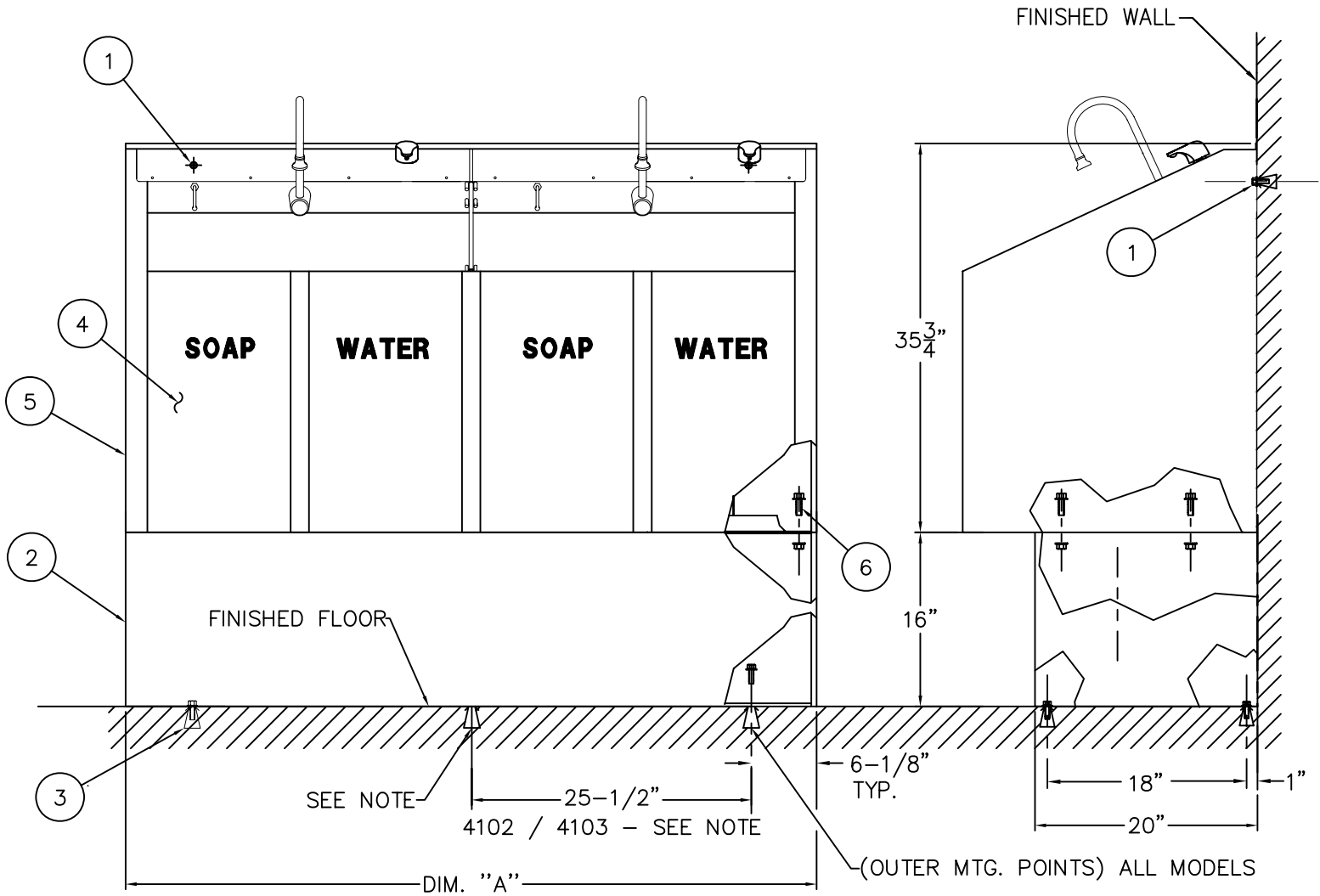

MODEL 4102 (2) PERSON SCRUB SINK SHOWN FOR REFERENCE ONLY, (1) AND (3) PERSON SCRUB SINKS ASSEMBLE THE SAME AS (2) PERSON.

INSTALLATION INSTRUCTIONS:

A- LOCATE AND INSTALL WALL ANCHORS (1) AS REQUIRED FOR APPROPRIATE MODEL. REFER TO ROUGH-IN SHEETS FOR 1/2" UNC WALL FASTENER LOCATION.

B- USING PEDISTAL (2) AS TEMPLATE LOCATE AND INSTALL 3/8" FLOOR ANCHORS (3) (BY OTHERS). SECURE PEDISTAL TO FLOOR WITH 3/8" DIA. FASTENERS (BY OTHERS).

C- REMOVE SIDE KNEE PANELS (4). POSITION SCRUB SINK (5) ON PEDISTAL (2) LINING UP (4) MOUNTING LOCATIONS. ASSEMBLE 1/4"-20 HEX-HEAD CAP SCREWS, WASHERS AND NUTS (6) PROVIDED.

MODEL	DIM. 'A'	ROUGH-IN
4101-PB	31-7/8"	9930-000-002
4102-PB	63-1/4"	9930-001-002
4103-PB	93-7/8"	9930-002-002

NOTE:

4101 MODEL INCLUDES (2) FLOOR MOUNTING POINTS (OUTER MOUNTING POINTS).
 4102 MODEL INCLUDES (3) FLOOR MOUNTING POINTS AS SHOWN.
 4103 MODEL INCLUDES (4) FLOOR MOUNTING POINTS - ADDITIONAL MOUNTING POINTS ARE AT 25-1/2" FROM OUTER MOUNTING POINTS.

 WHITEHALL MANUFACTURING P.O. BOX 3527 Industry, CA 91744 15125 Proctor Ave Industry, CA 91746 (626) 968-6681 FAX (626) 855-4862	TITLE SUFFIX -PB PEDESTAL BASE TO SCRUB SINK ASSEMBLY 4101, 4102, 4103		
	MANUFACTURE DATE FEBRUARY 2012 TO PRESENT	DATE ISSUED 02/17/12	DRAWING NUMBER 9930-009-002
		DATE REVISED	

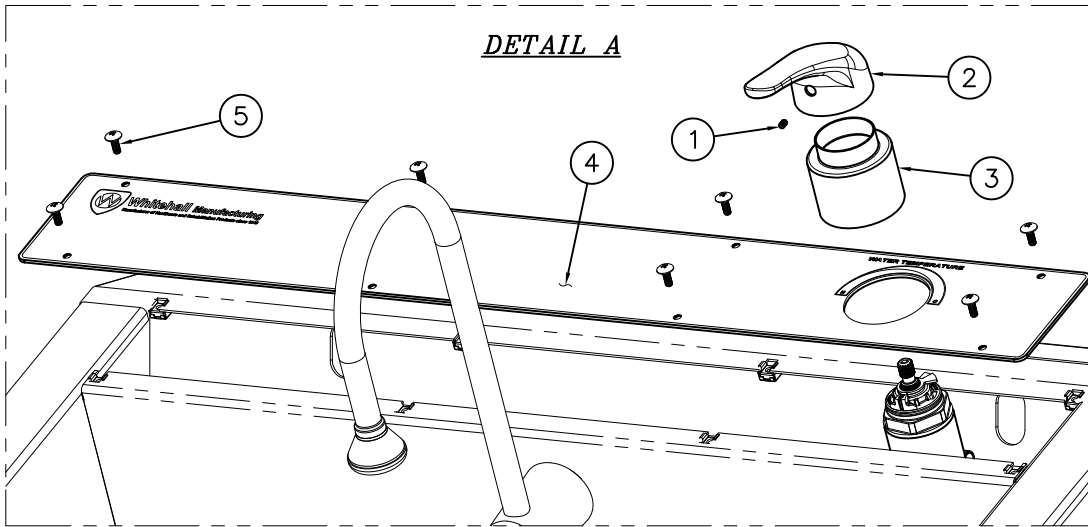

REFERENCE DRAWINGS	
ASSEMBLIES	NUMBER
T/P VALVE	9975-007-001

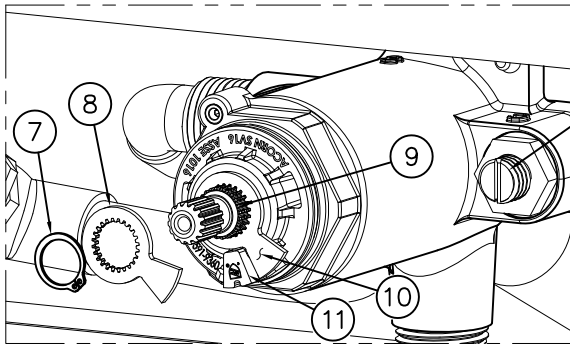

DETAIL B

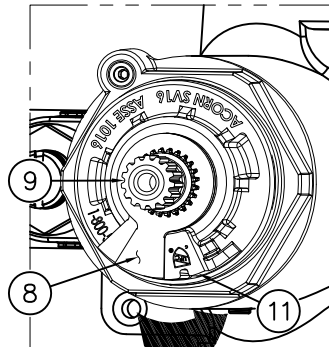

DETAIL C

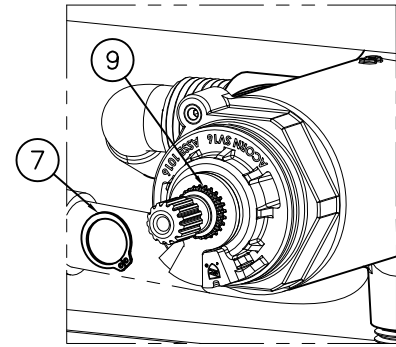

DETAIL D

INSTRUCTIONS:

SEE DETAIL A

A-REMOVE LEVER HANDLE TRIM: SEE DETAIL A

a-USING A 5/64" ALLEN WRENCH, BY OTHERS, REMOVE HANDLE SCREW (1) AND HANDLE (2).

b-PULL OFF VALVE SLEEVE (3).

c-REMOVE CONTROL PANEL (4) BY REMOVING SCREWS (5).

TEMPERATURE ADJUSTMENT:

B-ENSURE MAIN WATER SUPPLY IS ON.

C-ENSURE CHECK STOPS (6) ARE OPEN.

D-ENSURE VALVE IS IN THE OFF POSITION.

E-USING SNAP RING PLIERS REMOVE RETAINING RING (7) AND THE FIRST TEMPERATURE LIMIT WASHER (8) ONLY FROM VALVE STEM (9). SEE DETAIL B.

NOTE: IF SECOND TEMPERATURE LIMIT WASHER (10) COMES OFF, RESETTING OF THE OFF STOP MAY BE REQUIRED, KEY AS CLOSE AS POSSIBLE ON THE COUNTER-CLOCKWISE SIDE OF BONNET STOP (11). USING HANDLE (2) SLIGHTLY OPEN AND CLOSE VALVE TO ENSURE WATER WILL SHUT OFF. DETAIL B.

TEMPERATURE ADJUSTMENT; CONTINUED:

F-USING HANDLE (2) TURN VALVE STEM (9) COUNTER -CLOCKWISE TO INCREASE HOT, CHECKING OUTLET TEMPERATURE UNTIL DESIRED TEMPERATURE IS REACHED, (RECOMMENDED 105° TO 110°). SLIDE FIRST TEMPERATURE LIMIT WASHER (8) OVER VALVE STEM (9) AND ENSURE SIDE OF WASHER RESTS AS CLOSE AS POSSIBLE TO CLOCKWISE SIDE OF BONNET LIMIT STOP (11). DETAIL C.

G-WITH VALVE IN THE "ON" POSITION AND WATER RUNNING, USING SNAP RING PLIERS INSTALL RETAINING RING (7). ENSURE RETAINING RING (7) IS INSERTED PROPERLY INTO GROOVE ON VALVE STEM (9). DETAIL D.

H-REINSTALL TRIM IN REVERSE ORDER.



WHITEHALL MANUFACTURING
P.O. BOX 3527 Industry, CA 91744
15125 Proctor Ave Industry, CA 91746
(626) 968-6681 FAX (626) 855-4862

TITLE

MIXING VALVE TEMPERATURE ADJUSTMENT

MANUFACTURE DATE

**OCTOBER 2014
TO PRESENT**

DATE ISSUED

10/16/14

DATE REVISED

DRAWING NUMBER

9900-008-001



WARNING: HOT WATER WILL BE FLOWING OUT OF SOAP DISPENSER WHEN BEING FLUSHED.

AVERTISSEMENT: DE L'EAU CHAUDE S'ÉCHAPPERA DU DISTRIBUTEUR À SAVON PENDANT LA VIDANGE.

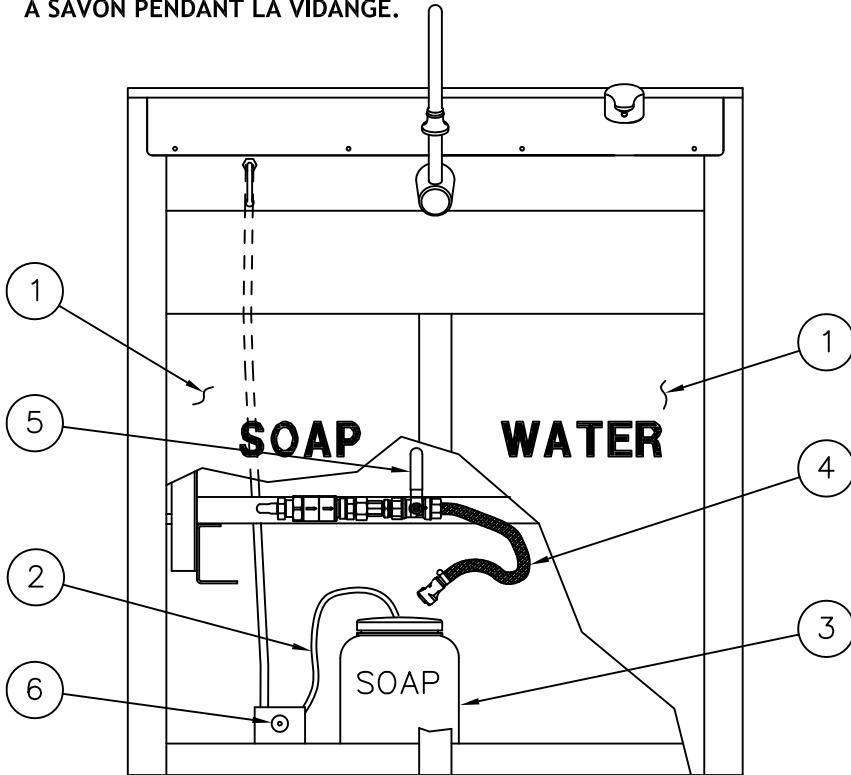

SUGGESTED EQUIPMENT:

- 1- BUCKET OR PAN FOR DRAINING EXCESS WATER FROM SOAP SYSTEM AFTER FLUSHING.
- 2- PAPER TOWELS OR RAGS FOR WIPING UP ANY WATER OR SOAP WHICH MIGHT SPILL DURING FLUSHING OPERATION.

OPERATING INSTRUCTIONS:

- A- REMOVE DOORS (1) (AS REQUIRED) TO GAIN ACCESS TO HOT WATER SOAP FLUSH SYSTEM.
- B- REMOVE DESIRED SOAP SUPPLY LINE (2) FROM SOAP BOTTLE (3) (BY OTHERS) AND CLEAN ANY EXCESS SOAP OFF SUPPLY LINE AND QUICK DISCONNECT FITTING.
- C- CONNECT QUICK DISCONNECT FITTING ON DESIRED SOAP SUPPLY LINE (2) TO QUICK DISCONNECT COUPLING ON SOAP FLUSH LINE (4).

CAUTION! SYSTEM USES HOT WATER - TAKE CARE WHEN OPERATING.

AVERTISSEMENT! LE SYSTÈME UTILISE DE L'EAU CHAUDE - SOYEZ PRUDENT LORS DE SON UTILISATION.

- D- SLOWLY OPEN BALL VALVE (5) AND FLUSH DESIRED SOAP LINE (2) UNTIL ALL SOAP HAS CLEARED SYSTEM. OBSERVE SYSTEM FOR ANY LEAKS WHILE FLUSHING. IF ANY LEAKS OCCUR WHILE FLUSHING, IMMEDIATELY SHUT OFF SYSTEM AND CHECK LEAKING CONNECTION FOR TIGHTNESS. IF LEAK CONTINUES, CONTACT OUR FIELD SERVICE DEPARTMENT FOR ASSISTANCE.

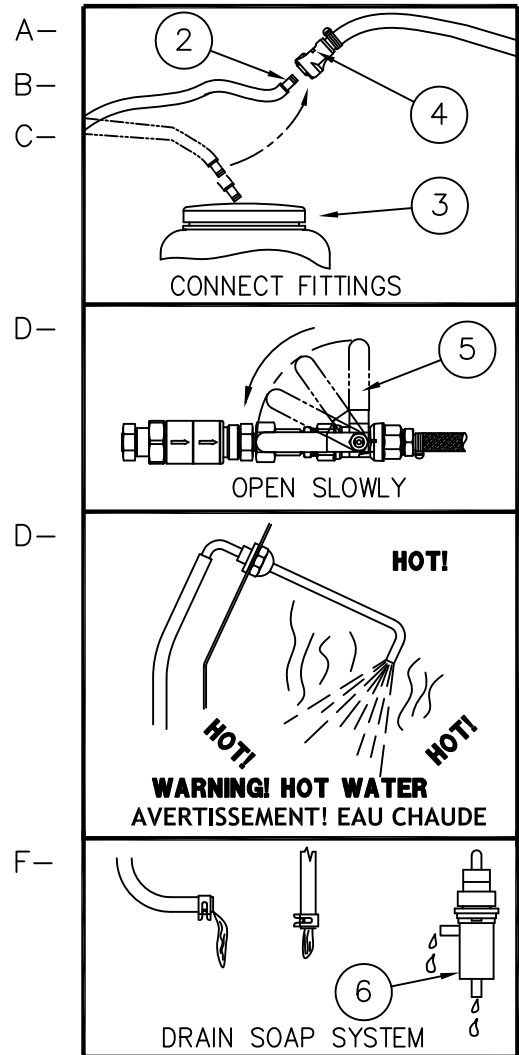

- E- AFTER FLUSHING OPERATION IS COMPLETED TURN OFF BALL VALVE (5). IF OTHER SOAP SUPPLY LINES NEED FLUSHING, DISCONNECT QUICK DISCONNECT FITTINGS AND REPEAT INSTRUCTIONS.

WARNING! DUE TO PRESSURE IN THE SYSTEM, HOT WATER WILL SQUIRT OUT WHEN Q.D. FITTINGS ARE DISCONNECTED, DRAIN EXCESS WATER FROM LINE.

AVERTISSEMENT! EN RAISON DE LA PRESSION CONTENUE DANS LE SYSTÈME, DE L'EAU CHAUDE GICLERA LORSQUE VOUS DÉBRANCHEZ LES RACCORDS RAPIDES. DRAINEZ LE TROP-PLEIN D'EAU DU CONDUIT.

- F- ONCE SOAP LINE OR LINES HAVE BEEN FLUSHED AND SOAP FLUSH LINE (4) HAS BEEN DISCONNECTED, OPEN SOAP PUMP (6) AND DRAIN SOAP SYSTEM OF WATER LEFT IN SYSTEM. CHECK PUMP O-RINGS FOR EXCESSIVE WEAR (REPLACE O-RINGS IF NECESSARY). RE-ASSEMBLE PUMP.
- G- PLACE SOAP SUPPLY LINE (2) BACK IN SOAP BOTTLE AND PUMP SOAP THROUGH SYSTEM UNTIL IT FLOWS FROM DISPENSER. RE-INSTALL DOORS WHEN COMPLETE.

WHITEHALL MANUFACTURING
P.O. BOX 3527 Industry, CA 91744
15125 Proctor Ave Industry, CA 91746
(626) 968-6681 FAX (626) 855-4862

TITLE		
HOT WATER SOAP FLUSH SYSTEM OPERATING INSTRUCTIONS (-SFS)		
MANUFACTURE DATE	DATE ISSUED	DRAWING NUMBER
FEBRUARY 2012	02/17/12	9930-020-002
TO PRESENT	DATE REVISED	
	10/14/15 A	

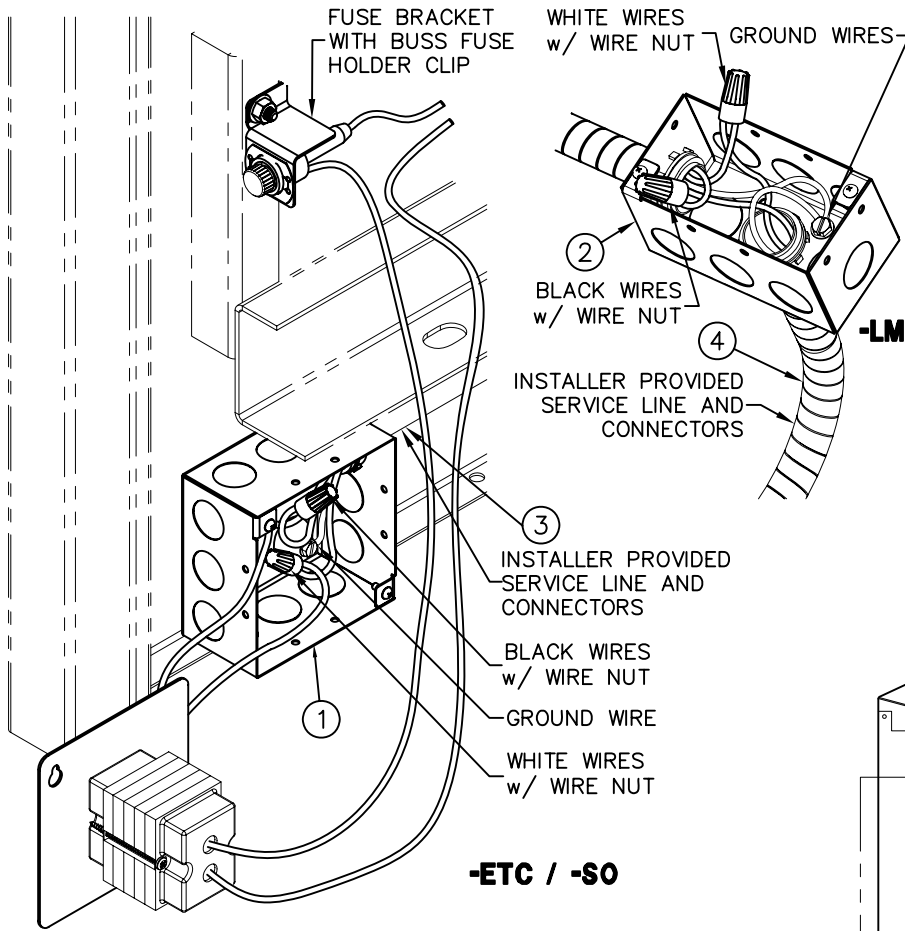

REFERENCE DRAWINGS	
TIMING VALVE	9982-010-003
ROUGH-IN DRAWINGS	
1 STATION	9930-000-002
2 STATION	9930-001-002
3 STATION	9930-002-002
TRANSFORMER & CONTROL PANEL	9982-015-001
DIGITAL TIMER ASSY.	9982-012-001

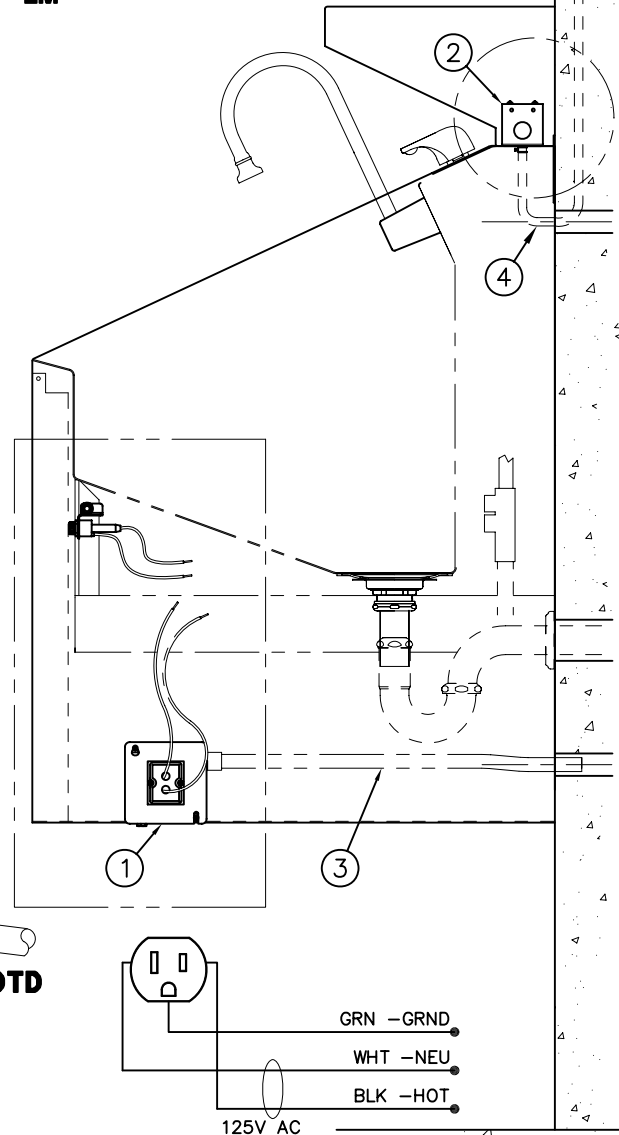

INSTALLATION INSTRUCTIONS:

A- REFER TO APPROPRIATE INSTALLATION SHEETS TO LOCATE & ROUGH-IN ELECTRICAL SERVICE LINES TO THE OPERATION CONTROL POWER SUPPLY, 4" x 4" J-BOX ① PROVIDED AND OPTIONAL -LM LIGHT MODULE, 4" x 2" J-BOX ② PROVIDED INSIDE HOUSING. USE ELECTRICAL CONDUIT OR ROMEX JACKETED CABLE TO PROVIDE ELECTRICAL SERVICE.

B- OPERATION CONTROL: RUN ELECTRICAL SERVICE CONDUIT OR ROMEX CABLE ③ TO POWER SUPPLY J-BOX ①. CONNECT WIRES AS SHOWN. USE APPROPRIATE SIZE WIRE NUTS FOR THE BLACK AND WHITE WIRE CONNECTIONS. CONNECT GROUND WIRE TO GROUND SCREW INSIDE J-BOX ①. REPLACE TRANSFORMER PLATE ONTO JUNCTION BOX WITH SCREWS PROVIDED.

C- LIGHT MODULE: RUN ELECTRICAL SERVICE CONDUIT OR ROMEX CABLE ④ FROM SWITCHED CIRCUIT TO 4" x 2" J-BOX ② INSIDE LIGHT MODULE HOUSING. SWITCH SHOULD BE LOCATED NEAR UNIT. REPLACE COVER PLATE TO J-BOX ②.

IMPORTANT: PROVIDE A SEPARATE 15A MIN. SERVICE LINE FOR EACH JUNCTION BOX IN THE SCRUB SINK. ALL SUPPLY LINES SHALL BE GFCI PROTECTED PER THE REQUIREMENTS OF NEC (NATIONAL ELECTRICAL CODE).



WHITEHALL MANUFACTURING
P.O. BOX 3527 Industry, CA 91744
15125 Proctor Ave Industry, CA 91746
(626) 968-6681 FAX (626) 855-4862

TITLE SCRUB SINK WITH SUFFIX OPTION -DTD, -ETC, -LM AND -SO DETAIL		
MANUFACTURE DATE FEBRUARY 2012 TO PRESENT	DATE ISSUED 02/17/12	DRAWING NUMBER 9930-021-003
	DATE REVISED	

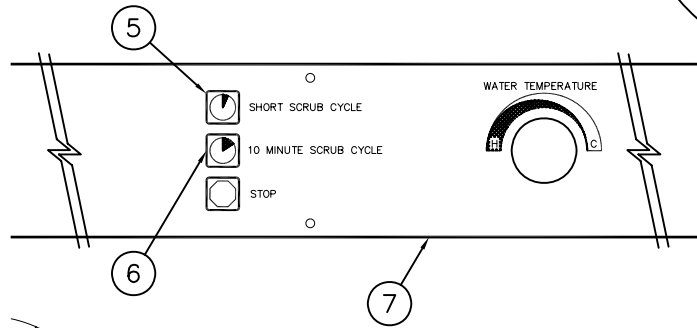
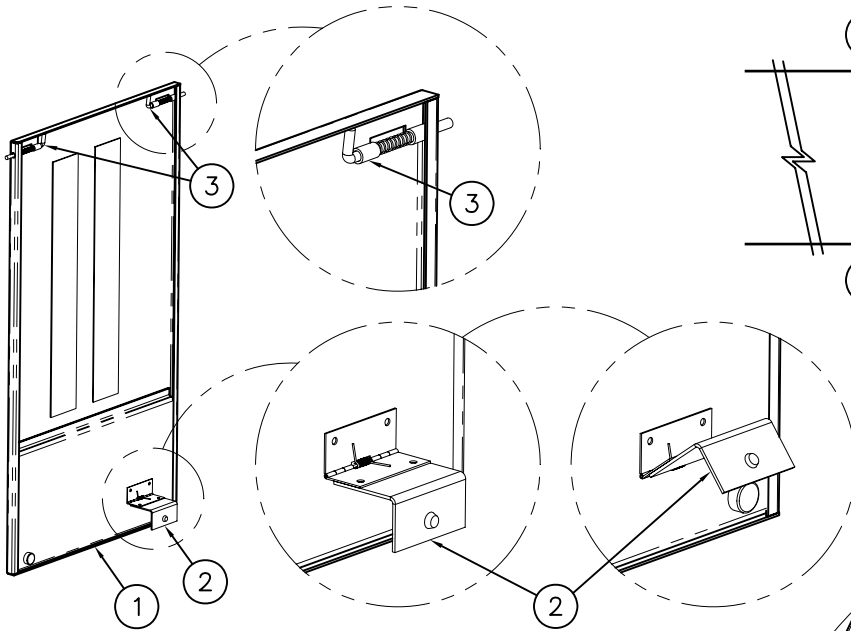

*FIXTURES ARE FACTORY SET WITH SHORT SCRUB CYCLE SET TO 5 MINUTES AND 10 MINUTE SCRUB CYCLE SET TO 10 MINUTES.

LABEL AFFIXED TO THE INSIDE OF THE -ETC COVER (4)

SHORT TIMER (SET SWITCHES 5,6,7,8)																
MINUTES REQUIRED	2.5	5.0	7.5	1.0	1.5	2.0	2.5	3.0	3.5	4.0	4.5	5.0	5.5	6.0	6.5	7.0
8	ON	OFF	ON	OFF	ON	OFF	ON	OFF	ON	OFF	ON	OFF	ON	OFF	ON	OFF
7	ON	ON	OFF	OFF	ON	ON	OFF	OFF	ON	ON	OFF	OFF	ON	ON	OFF	OFF
6	ON	ON	ON	ON	OFF	OFF	OFF	OFF	ON	ON	ON	ON	OFF	OFF	OFF	OFF
5	ON	ON	ON	ON	ON	ON	ON	ON	OFF	OFF	OFF	OFF	OFF	OFF	OFF	OFF
4	ON	OFF	ON	OFF	ON	OFF	ON	OFF	ON	OFF	ON	OFF	ON	OFF	ON	OFF
3	ON	ON	OFF	OFF	ON	ON	OFF	OFF	ON	ON	OFF	OFF	ON	ON	OFF	OFF
2	ON	ON	ON	ON	ON	ON	ON	ON	ON	ON	ON	ON	ON	ON	ON	ON
1	ON	ON	ON	ON	ON	ON	ON	ON	ON	ON	ON	ON	ON	ON	ON	ON
MINUTES REQUIRED	2.5	3.0	3.5	4.0	4.5	5.0	5.5	6.0	6.5	7.0	7.5	8.0	8.5	9.0	9.5	10

LONG TIMER (SET SWITCHES 1,2,3,4)

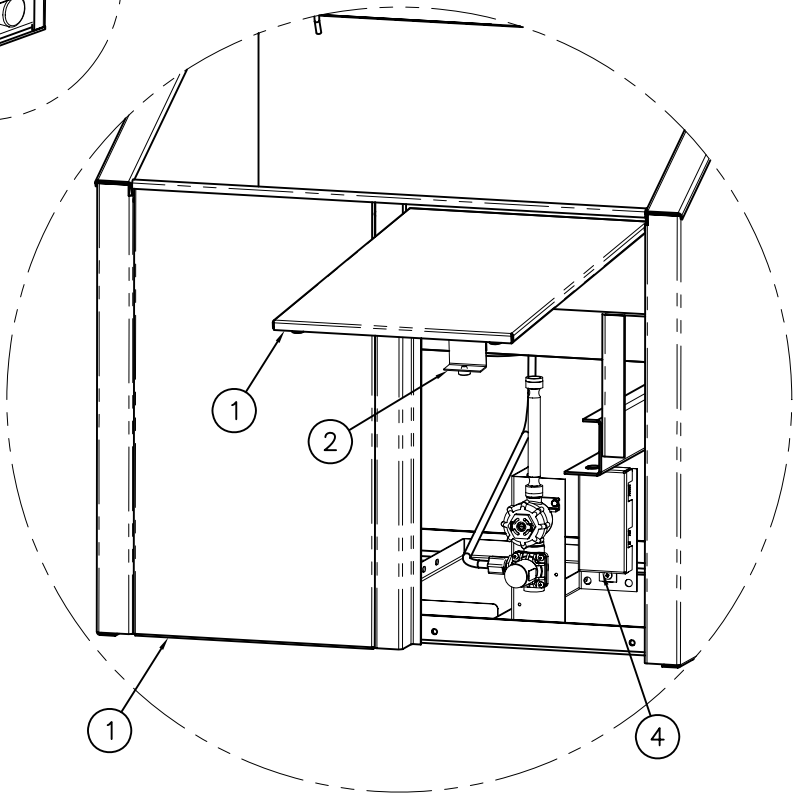

ADJUSTMENT INSTRUCTIONS:

A- TO REMOVE KNEE PANEL (1): PUSH THE BOTTOM OF THE PANEL WHILE SIMULTANEOUSLY REACHING UNDERNEATH THE FIXTURE AND UP BEHIND THE PANEL TO LIFT UP LOCK LATCH (2) TO DISENGAGE. SUPPORT KNEE PANEL OUT OF THE WAY AND MOVE LEFT & RIGHT HINGE PIN LEVERS (3) TOWARD CENTER TO FREE AND REMOVE PANEL COMPLETELY.

B- LOCATE AND REMOVE ELECTRONIC TIMER CONTROLLER COVER (4) BY REMOVING SCREW.

C- DETERMINE DESIRED MINUTES REQUIRED FOR APPROPRIATE TIMING CYCLE.

D- TO CHANGE THE DURATION OF THE SHORT SCRUB CYCLE TIMING USE THE DIP SWITCH SET INDICATED "SHORT TIMER" (5) SETTINGS. TO CHANGE THE 10 MINUTE SCRUB CYCLE TIMING CHANGE THE DIP SWITCH SET INDICATED "LONG TIMER" (6) SETTINGS. SET TIMING BY SETTING INDIVIDUAL DIP SWITCHES FOR THE APPROPRIATE SET, AS INDICATED FOR THE TIMING DESIRED.

E- AFTER SETTING SWITCHES AS DESIRED, TEST BY SELECTING THE APPROPRIATE TOUCH SCREEN INDICATOR ON THE CONTROL PANEL (7).

F- REPLACE KNEE PANEL IN REVERSE ORDER ABOVE.

WHITEHALL MANUFACTURING P.O. BOX 3527 Industry, CA 91744 15125 Proctor Ave Industry, CA 91746 (626) 968-6681 FAX (626) 855-4862	TITLE TIMING ADJUSTMENT FOR ELECTRONIC TIME CONTROLLER (-ETC)	
	MANUFACTURE DATE FEBRUARY 2012 TO PRESENT	DATE ISSUED 02/17/12
	DATE REVISED	



PRELIMINARY STEPS:

1. Flush water supply line prior to installation. This will remove unwanted debris from the lines and prevent unwanted blockages in the safety equipment.
2. In order to comply with ANSI Z358.1, the safety equipment must be inspected periodically. An inspection tag is provided for documentation purposes.
3. All employees at risk of eye contamination should be informed and trained in the use of this and any other safety equipment. The signage provided should be posted appropriately in close proximity as required by ANSI and OSHA.
4. Position sign with clear visibility, in close proximity to safety equipment and mark mounting hole locations.
5. Select appropriate 1/4" anchors, screws and washers (supplied by others) to install signage.
6. Attach inspection tag supplied with plastic zip tie. ANSI

OPERATION INSTRUCTIONS:

Employees who work with hazardous materials should become familiar with the location and operation of the nearest emergency plumbing fixture. Emergency plumbing fixtures stations are simple to use and require hands free operation once the station is activated. Regular instruction regarding proper care and use will increase confidence that the units are accessible and function properly.

The route and area surrounding the Eye Wash should be clear and unobstructed; the sooner eyes are flushed, the less likelihood of damage. Eye Wash stations should be located in close proximity to the hazard and take no more than 10 seconds to reach. In the case of severe eye contamination the victim may require assistance to the Eye Wash station and help flushing their eyes.

Safety plumbing fixture equipment should be operated weekly for a period long enough to verify operation, clear the supply line of any sediment build-up and minimize microbial contamination due to sitting water.

1. To start the Eye Wash, swing spray nozzle assembly down horizontally over the basin or fully "ON" position. Flushing should start, popping the spray nozzle caps open.
2. Lower both eyes into flow. Both eyes should be flushed to prevent contamination from one eye from being delivered to unaffected eye. Personnel who wear contact lenses should remove them immediately prior to or during the flush to prevent the contamination from remaining against the cornea possibly causing unnecessary damage or pain.
3. Using thumb and forefingers, fully open eyelids and flush eyes thoroughly for approximately 15 minutes or until medical personnel arrive. Be prepared to let the doctor know what type of contamination has entered the eye.
4. When finished swing spray nozzle assembly up or fully "OFF" position. Flushing fluid should stop. Once flushing fluid has stopped flowing, return spray nozzle lids to the closed position to protect from airborne contaminants.

MAINTENANCE GUIDE:

Maintain and inspect in accordance with ANSI Z358.1-2009

1. Check for obvious signs of wear, broken or defective equipment. Re-paint if necessary. Replace missing or defective equipment such as broken push paddles, missing signs and inspection tags.
2. Remove strainer and washout any debris collected –replace as required.
3. Operate Eye Wash nozzles swinging the spray nozzle assembly down to place ball valve in the fully "ON" position checking for smooth operation of valve push paddle mechanism at the same time ensuring that the Eye Wash spray nozzle caps pop off immediately when actuated. If the ball valve does not operate smoothly check the actuating assembly for binding or missing parts. If the Eye Wash spray nozzle caps do not pop off immediately when actuated check for correct supply inlet pressure.
4. While in operation, inspect spray nozzles for clogs or debris correct or replace as required.
5. Swing spray nozzle assembly up to fully "OFF" position and swing back to stand by position. To prevent Eye Wash spray nozzles from becoming contaminated, always close nozzle lids after each use.



REPAIR PARTS:

NOTE:

Individual parts not available for purchase, sold in repair kits only. Parts called out for reference only.

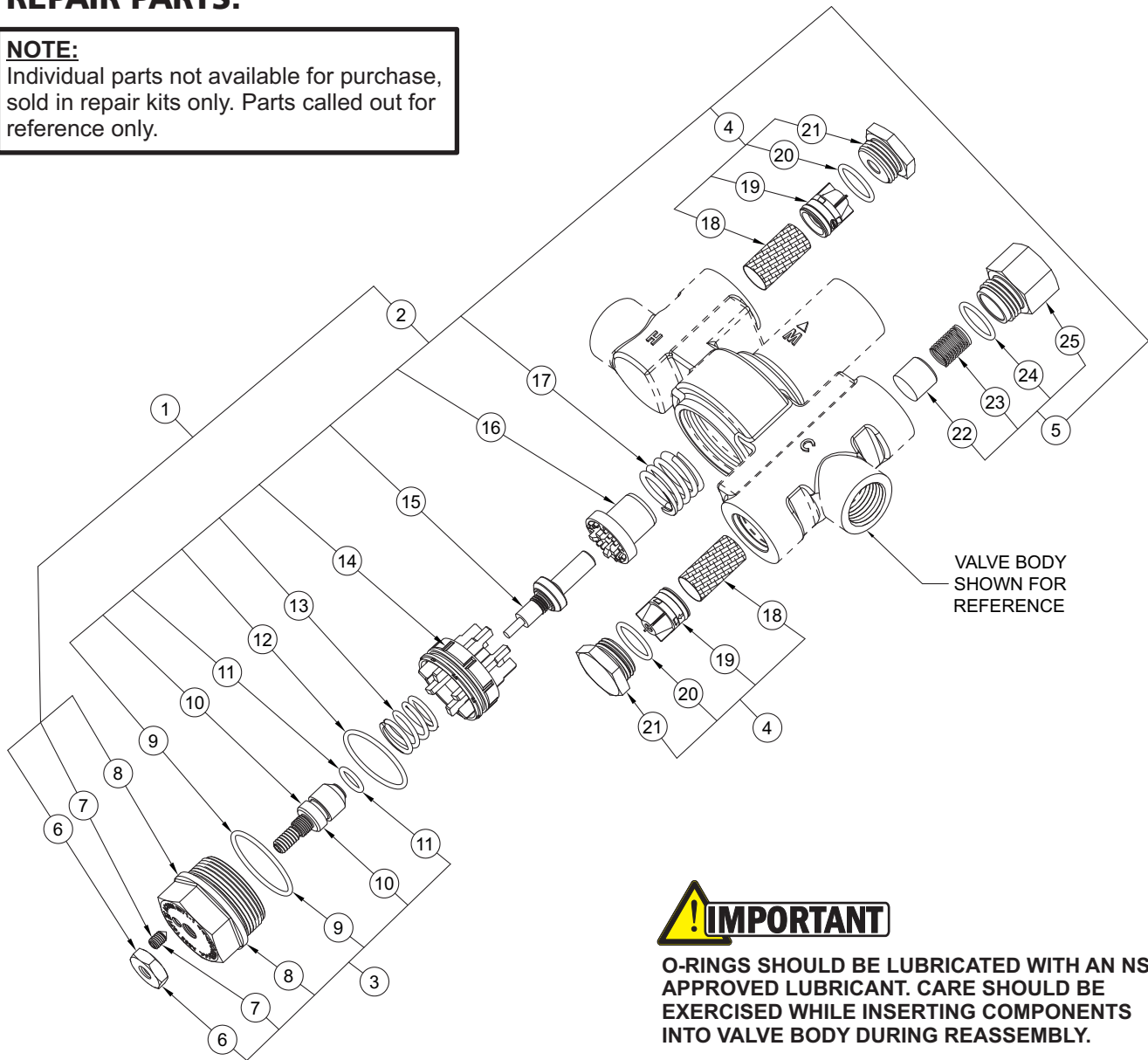

! IMPORTANT

O-RINGS SHOULD BE LUBRICATED WITH AN NSF APPROVED LUBRICANT. CARE SHOULD BE EXERCISED WHILE INSERTING COMPONENTS INTO VALVE BODY DURING REASSEMBLY.

ITEM	DESCRIPTION	ET71-1 KIT NUMBER
1	COMPLETE REBUILD KIT	7801-500-001
2	INTERNAL REPAIR KIT	7801-501-001
3	BONNET / STEM REPLACEMENT	7801-502-001
4	CHECK VALVE / STRAINER KIT	7801-503-001
5	BY-PASS REPAIR KIT	7801-504-001

ITEM	DESCRIPTION	ITEM	DESCRIPTION	ITEM	DESCRIPTION
6	ADJUSTMENT STEM LOCK NUT	13	UPPER SPRING	20	CHECK VALVE BONNET O-RING (x 2)
7	HIGH TEMPERATURE LIMIT STOP	14	SHUTTLE	21	CHECK VALVE BONNET (x 2)
8	VALVE BONNET	15	THERMOSTATIC MOTOR	22	BY-PASS POPPET
9	BONNET O-RING	16	FUNNEL	23	BY-PASS SPRING
10	ADJUSTMENT STEM	17	LOWER SPRING	24	BY-PASS BONNET O-RING
11	ADJUSTMENT STEM O-RING	18	INLET SCREEN (x 2)	25	BY-PASS BONNET
12	SHUTTLE O-RING	19	CHECK VALVE (x 2)		



ITEM #	PART NUMBER	DESCRIPTION
1	6410-208-005	SWING DOWN VALVE COVER, LH
2	7100-140-001	EYE WASH STRAINER ASSY
3	6410-208-004	SWING DOWN BRACKET ASSY, LH
4	7104-319-000	#8 HEX BUTTON HEAD SCREW
5	1932-010-000	3/8" NPT CLOSE NIPPLE
6	7104-047-001	SWING ARM VALVE ASSY
7	LABLE DISK, SWING ARM VALVE	
8	7104-207-199	RETAINING NUT
9	6410-208-002	CHROME SWING DOWN YOKE ASSY
10	7101-104-001	FACE WASH ASSEMBLY, LH

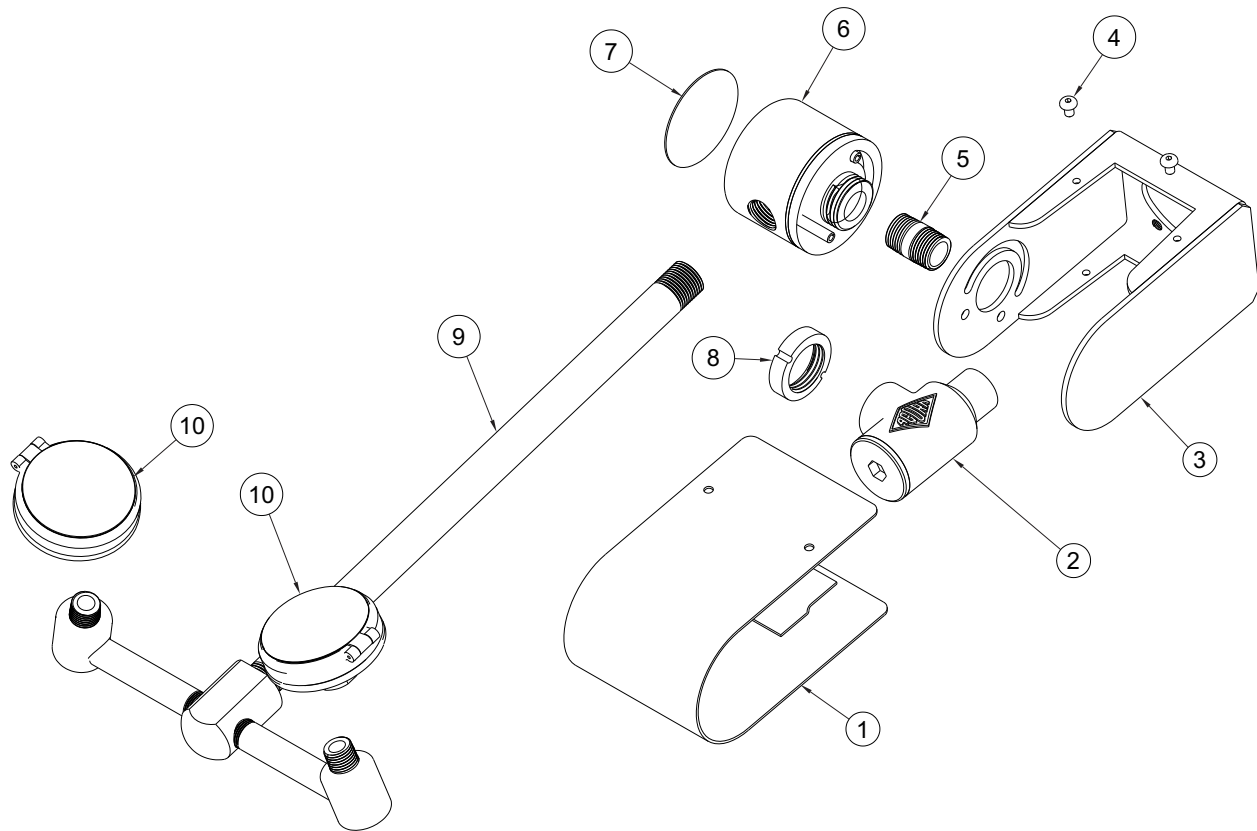



ITEM#	PART NUMBER	DESCRIPTION
1	6410-208-005	SWING DOWN VALVE COVER
2	7100-140-001	EYE WASH STRAINER ASSY
3	6410-208-003	SWING DOWN BRACKET ASSY, RH
4	7104-319-000	#8 HEX BUTTON HEAD SCREW
5	1932-010-000	3/8" NPT CLOSE NIPPLE
6	7104-047-001	SWING ARM VALVE ASSY
7	7104-045-150	LABLE DISK, SWING ARM VALVE
8	7104-207-199	RETAINING NUT
9	6410-208-002	CHROME SWING DOWN YOKE ASSY
10	7101-104-002	FACE WASH ASSEMBLY, LESS LID

