

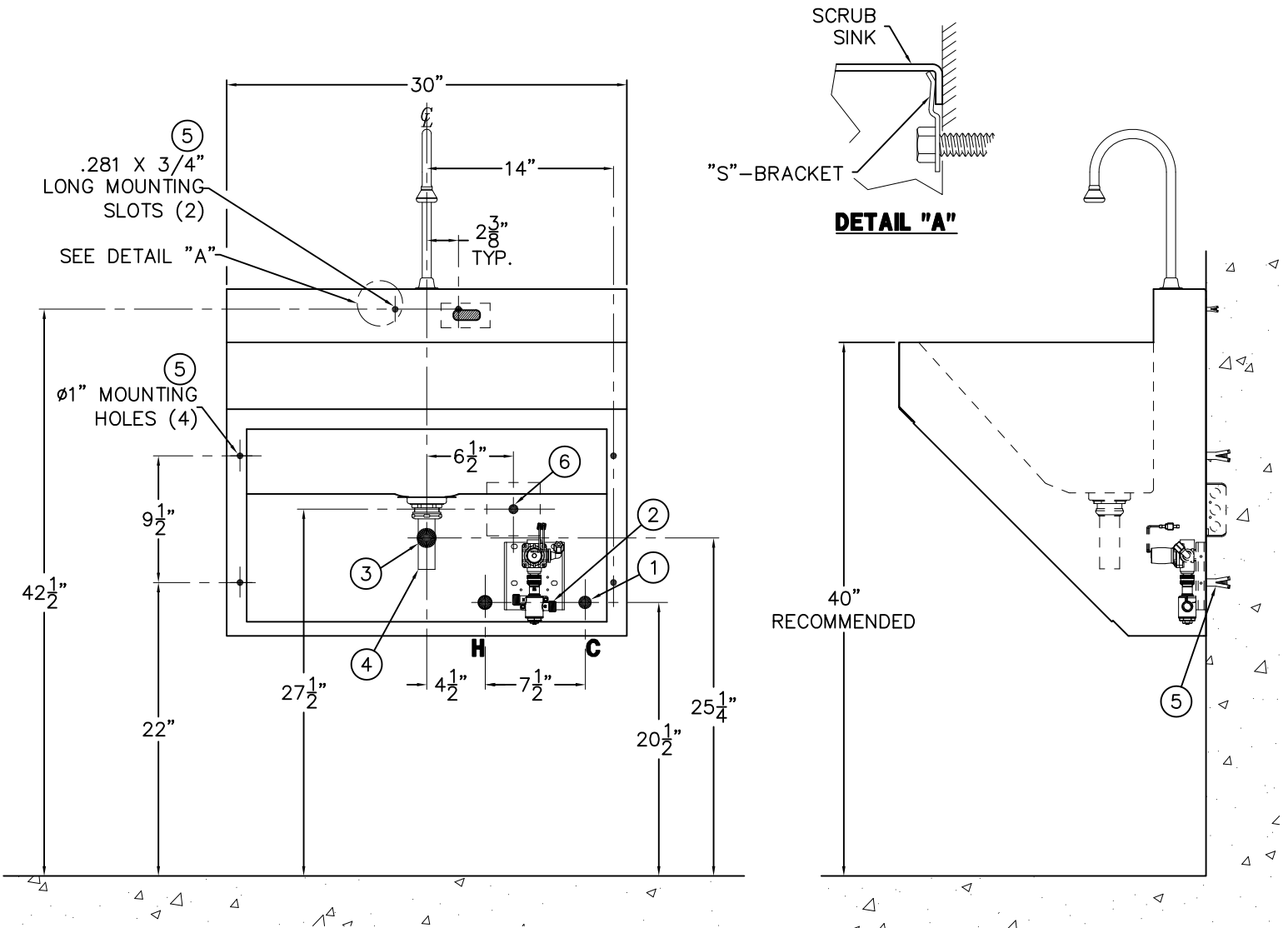

REFERENCE DRAWINGS
 -SO SENSOR INSTALL | 9930-004-002



INSTALLATION INSTRUCTIONS:

A- ROUGH-IN FOR THE FOLLOWING:

- HOT AND COLD SUPPLIES (1) FOR 1/2" NPS HOSE VALVE INLETS (2), VALVE SHIPPED LOOSE.
- P-TRAP (BY OTHERS) WASTE OUTLET (3) FOR 1-1/2" OD TAILPIECE (4) PROVIDED.
- MOUNTING POINTS (5) FOR WALL ANCHORS AND ANCHORING HARDWARE BY OTHERS.
- ELECTRICAL SERVICE (6) FOR 4" X 4" J-BOX (BY OTHERS) AND 24VAC TRANSFORMER SHIPPED LOOSE FOR FIELD INSTALLATION.

B- LAYOUT AND INSTALL WALL ANCHORS BY OTHERS AND ANCHORING S-CLIP PROVIDED. THREAD 1/2"-20 UNC STUDS BY OTHERS.

C- INSTALL J-BOX AND TRANSFORMER PLATE.

D- REMOVE ACCESS PANELS, POSITION FIXTURE INTO PLACE AND SECURE TO WALL USING WASHERS AND NUTS BY OTHERS. TORQUE NUTS TO 60 F-LBS. MAKE UP SUPPLY AND WASTE CONNECTIONS AS REQUIRED.

WARNING: SUPPLY LINES SHOULD BE FLUSHED OF ALL FOREIGN MATERIAL SUCH AS DOPE, CHIPS, SOLDER ETC. VALVE MUST BE DRAINED PRIOR TO BEING SUBJECTED TO FREEZING TEMPERATURES. MAXIMUM RECOMMENDED OUTLET WATER TEMPERATURE IS 105° F.

NOTE:

TRANSFORMER(S) MUST BE WIRED TO A GFI PROTECTED CIRCUIT. FIXTURE MUST BE EARTH GROUNDED PER N.E.C. (NATIONAL ELECTRICAL CODE)

	WHITEHALL MANUFACTURING P.O. BOX 3527 Industry, CA 91744 15125 Proctor Ave Industry, CA 91746 (626) 968-6681 FAX (626) 855-4862	TITLE	
	1 PERSON COMPACT SURGICAL SCRUB SINK #4111		
	MANUFACTURE DATE JANUARY 2012 TO PRESENT	DATE ISSUED 02/09/12	DRAWING NUMBER 9930-005-002
		DATE REVISED 10/15/19 C	



MODEL	DIM "A"
4111	28"
4112	58"
4113	88"

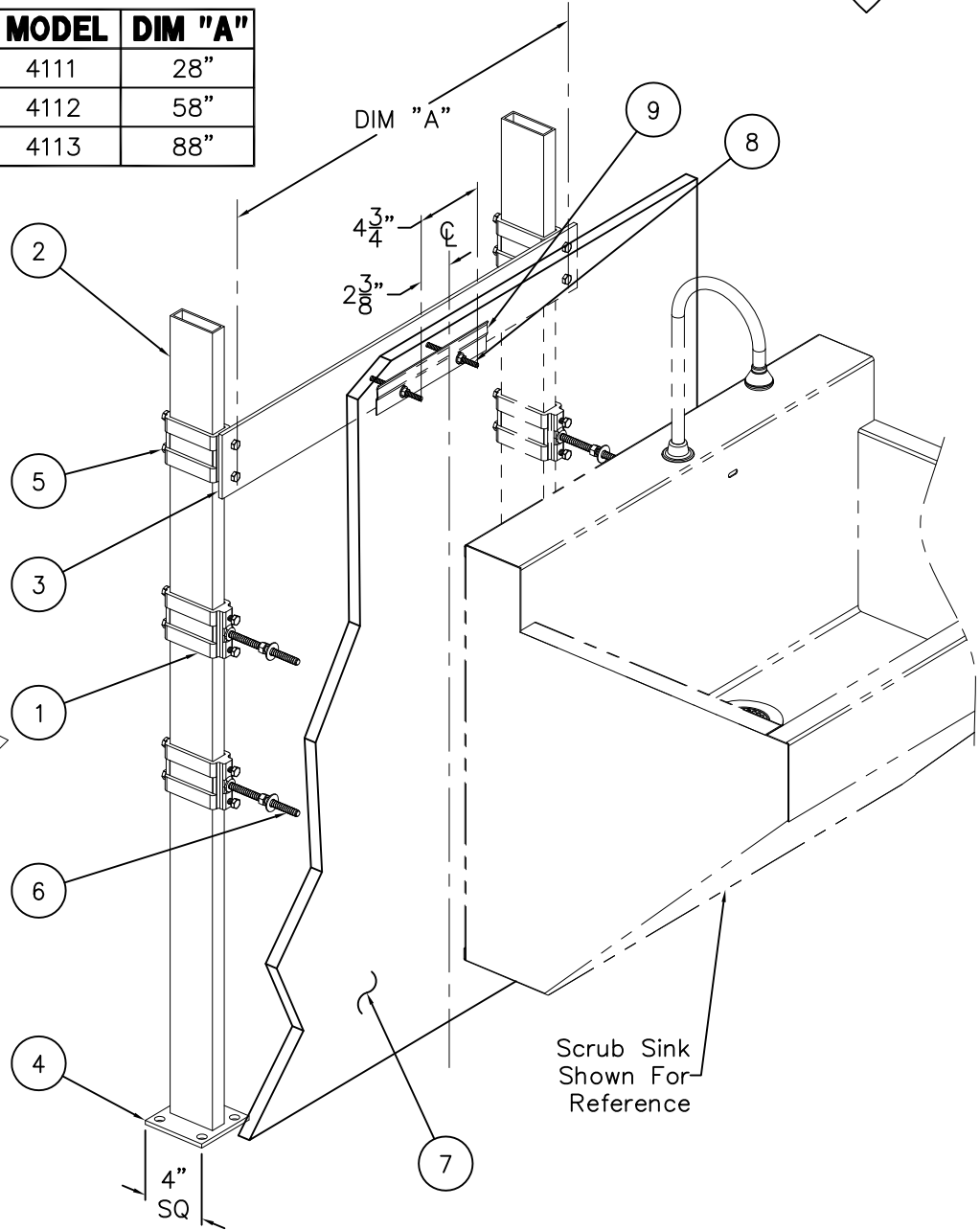
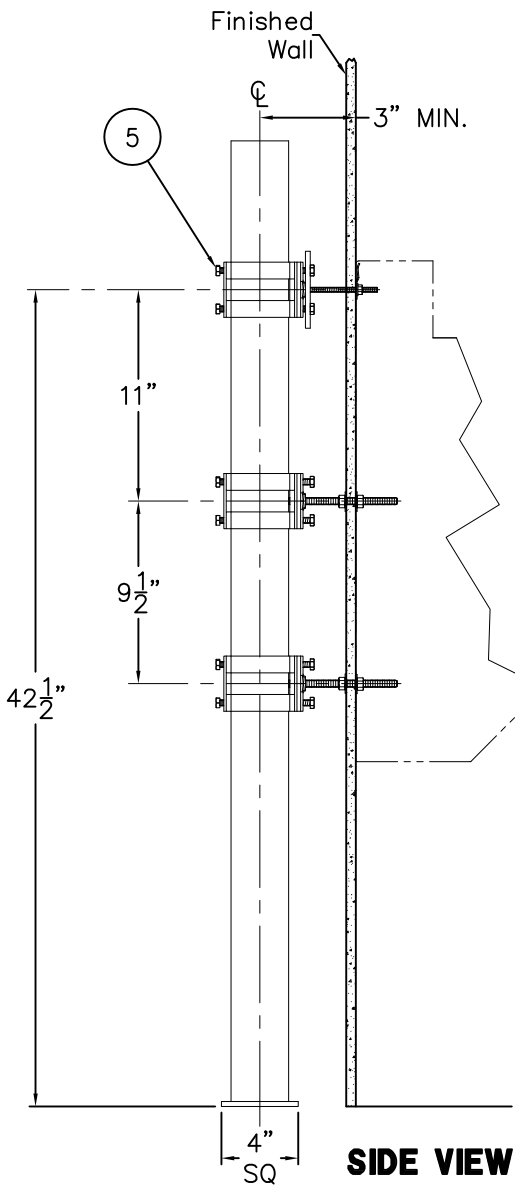

INSTALLATION INSTRUCTIONS:

- A- PRIOR TO INSTALLING FINISH WALL COVERING (7) ASSEMBLE -MC MOUNTING CARRIER.
- B- PLACE COLLARS (1) ON STANCHIONS (2) AND INSTALL HORIZONTAL SUPPORTS (3) ONTO STANCHIONS (2).
- C- ANCHOR SUPPORT BASES (4) TO A RIGID FLOOR OR OTHER RIGID SUBSTRUCTURE WITH 9/16" DIA. CAPNUTS & WASHERS (4) BY OTHERS.
- D- ADJUST COLLARS (1) TO PROPER HEIGHT AND TIGHTEN SET SCREWS (5).
- E- INSTALL WALL COVERING (7) ALLOWING ACCESS TO 3/8" MOUNTING STUDS (6) AND 1/4" STUDS (8) FOR "S" CLIP MOUNTING.
- F- INSTALL "S" CLIP MOUNTING BRACKET(S) (9) ON FINISHED FACE OF WALL (7).
- G- COMPLETE ANY NECESSARY ROUGH-IN CONNECTIONS (NOT-SHOWN) FOR SUPPLY AND WASTE PIPING. COMPLETE INSTALLATION OF FINISHED WALL AND MOUNT SCRUB SINK TO "S" CLIP(S) AND PROTRUDING STUDS.

 WHITEHALL MANUFACTURING P.O. BOX 3527 Industry, CA 91744 15125 Proctor Ave Industry, CA 91746 (626) 968-6681 FAX (626) 855-4862	TITLE -MC MOUNTING CARRIER INSTALLATION DETAIL		
	MANUFACTURE DATE JANUARY 1994 TO PRESENT	DATE ISSUED 05/01/00	DRAWING NUMBER 9930-008-001
		DATE REVISED 07/18/12	



TWO STATION WIRING DIAGRAM SHOWN

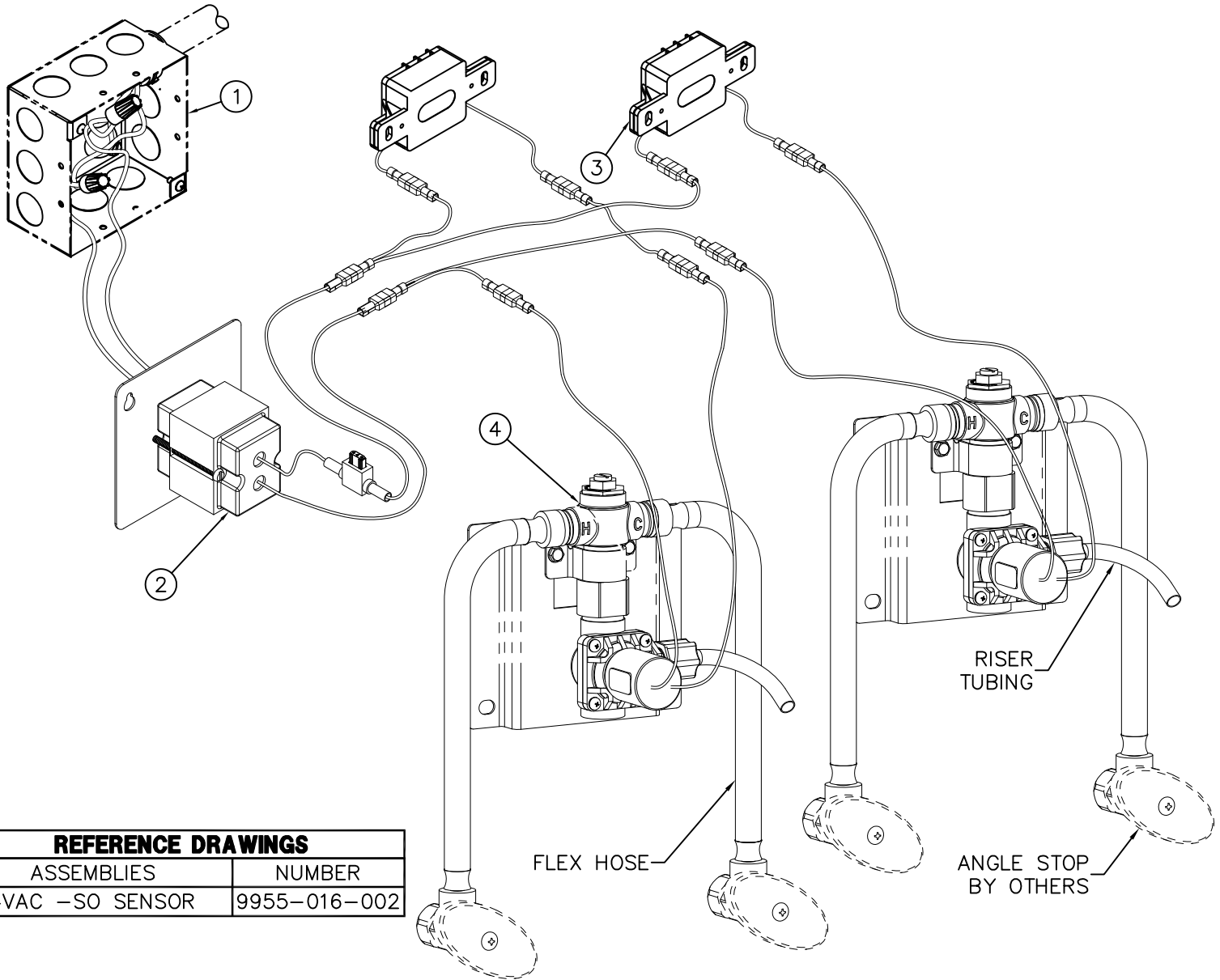

REFERENCE DRAWINGS	
ASSEMBLIES	NUMBER
24VAC -SO SENSOR	9955-016-002

INSTALLATION INSTRUCTIONS:

- A-REFER TO APPROPRIATE INSTALLATION SHEETS FOR PARTICULAR FIXTURE INSTALLATION AND ROUGH-IN INFORMATION.
- B-PROVIDE J-BOX ① WITH 120V, 60HZ, 3A MAX SERVICE TO CONNECT 24V, 50VA TRANSFORMER ② 4 X 4" PLATE PROVIDED.
- C-CONNECT TRANSFORMER WIRE SET TO SENSOR ③ HARNESS AND SOLENOID HARNESS. SENSORS ARE FACTORY INSTALLED.

NOTES:

- WALL ANCHORS AND ANCHORING HARDWARE ARE PROVIDED BY THE INSTALLER.
- TRANSFORMER ② AND VALVE ④ ARE SHIPPED LOOSE FOR FIELD MOUNTING WITH INSTALLER PROVIDED ANCHORING HARDWARE.
- TRANSFORMER ② MUST BE WIRED TO A GFCI PROTECTED CIRCUIT. FIXTURE MUST BE EARTH GROUNDED PER N.E.C. (NATIONAL ELECTRICAL CODE).

<p>WHITEHALL MANUFACTURING P.O. BOX 3527 Industry, CA 91744 15125 Proctor Ave Industry, CA 91746 (626) 968-6681 FAX (626) 855-4862</p>	<p>TITLE 24VAC -SO SENSOR INSTALLATION FOR COMPACT SCRUB SINK</p>		
	<p>MANUFACTURE DATE</p> <p>JANUARY 2012</p> <p>TO PRESENT</p>	<p>DATE ISSUED</p> <p>02/09/12</p>	<p>DRAWING NUMBER</p> <p>9930-004-002</p>
		<p>DATE REVISED</p> <p>06/25/13 C</p>	



NOTE: RANGE OF MOTION FOR ADJUSTMENT SCREW IS FROM APPROX. 8 O'CLOCK CLOCKWISE TO APPROX. 4 O'CLOCK.

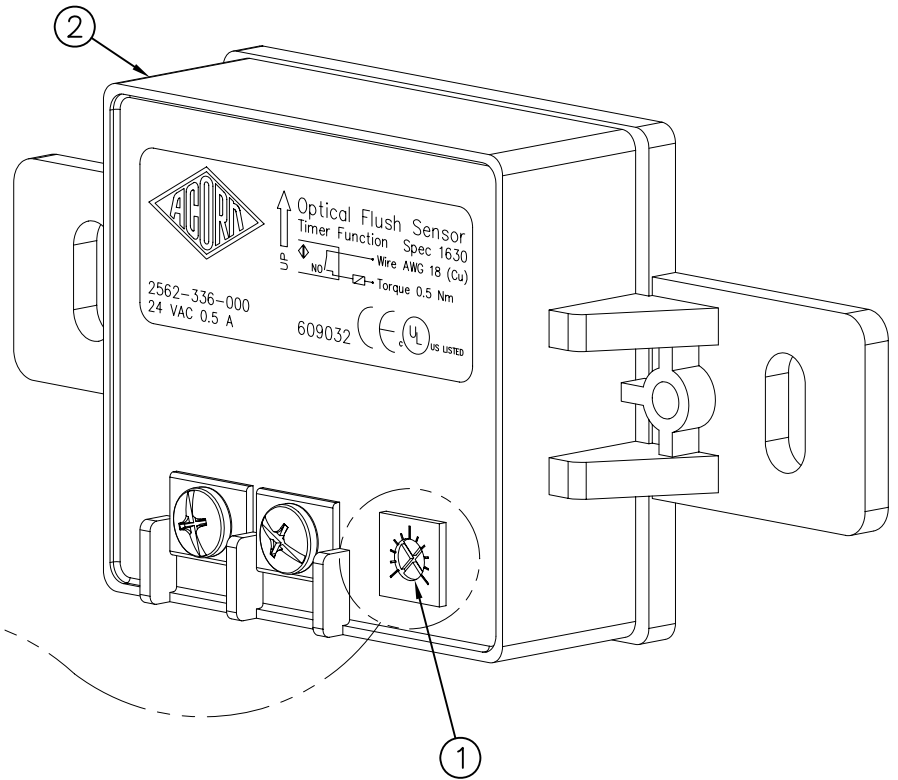

INCREASE

DECREASE

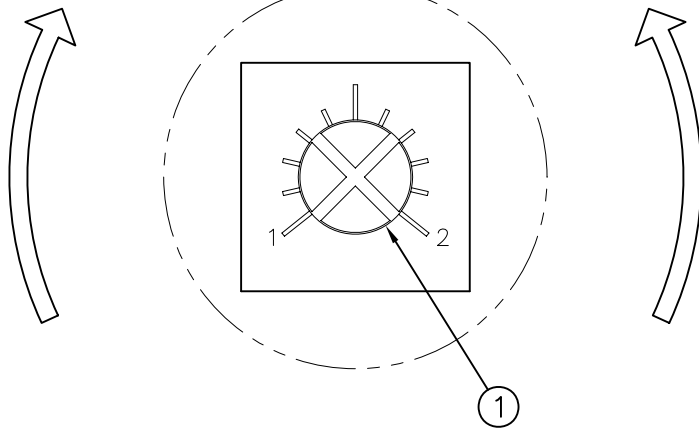

RANGE ADJUSTMENT INSTRUCTIONS:

A- USE SMALL JEWELERS CROSS TIP SCREW DRIVER TO ADJUST SENSOR RANGE (1) ON BACK OF SENSOR (2).

B- TURN ADJUSTMENT SCREW (1) CLOCKWISE TO INCREASE SENSOR RANGE.

C- TURN ADJUSTMENT SCREW (1) COUNTERCLOCKWISE TO DECREASE SENSOR RANGE.

D- NOTE: SENSOR RANGE IS FROM 0 TO APPROXIMATELY 24" MAXIMUM.



ACORN ENGINEERING COMPANY
P.O. BOX 3527 Industry, CA 91744
15125 Proctor Ave Industry, CA 91746
(626) 336-4561 FAX (626) 961-2200

TITLE 24VAC SENSOR RANGE ADJUSTMENT		
MANUFACTURE DATE JUNE 2002 TO PRESENT	DATE ISSUED 02/22/08	DRAWING NUMBER 9940-011-001
	DATE REVISED 02/09/12	



START UP MODE:

The Acorn -SO is a 24VAC sensor and includes a manual range adjustment. Sensor range adjustments may be made using adjustment screw on back of sensor.



The Start Up Mode will take approximately five (5) minutes to complete its full cycle and it is important that no target is present in front of the sensor during this time. A steady red light visible in the center of the oval sensor window indicates the sensor is in Start Up Mode. If the red light is flashing, this indicates that the sensor is picking up a target. Unless this target is a permanent fixture in the sensor's environment (i.e. a wall or stall door) it must be removed from the view of the sensor. If this target is permanent the sensor will attempt to adapt itself around this target. When Start Up Mode is complete the steady red light will go off.

NOTE:

1. If the 24VAC power supply is interrupted for more than fifteen (15) seconds the Start Up Mode will automatically repeat itself when the power is restored.
2. If the indicator light flashes three (3) times quickly, then three (3) times slowly and continues to repeat this sequence, this indicates incorrect wiring or a short in the 24VAC power supply.

NORMAL VALVE FUNCTION:

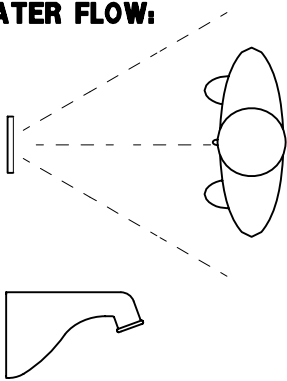
One second time delay when sensor is activated by user. Time of flow is 30 seconds. To reactivate, the user must move out of and return to the sensing area. When installed in the shower, flow continues indefinitely until user moves from sensing area.

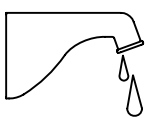
CONDITION:	PROBABLE CAUSE
<p>NO WATER FLOW:</p> 	<ol style="list-style-type: none"> 1.1 Stops or main water supply may be closed. 1.2 When using -T/P mixing valve, both supplies must be open to supply adequate water flow. 1.3 Clogged strainer. 1.4 Clogged water diaphragm. 1.5 Loose wiring connections. 1.6 Blown fuse at transformer. 1.7 Circuit breaker shut off.
<p>WATER WON'T SHUT OFF</p> 	<ol style="list-style-type: none"> 2.1 Adjacent objects may be triggering the sensor. 2.2 Sensor malfunction.
<p>WATER DRIPS</p> 	<ol style="list-style-type: none"> 3.1 Clogged water diaphragm.

MINIMUM / MAXIMUM WATER PRESSURE (PSI) 30 / 125. MAXIMUM WATER TEMPERATURE 130°F.

Refer to drawing #9955-016-002 for parts breakdown of items listed above.

Refer to Acorn Operations And Maintenance Manual for installation instructions and repair parts.

 <p>ACORN ENGINEERING COMPANY P.O. BOX 3527 Industry, CA 91744 15125 Proctor Ave Industry, CA 91746 (626) 336-4561 FAX (626) 961-2200</p>	TITLE		
	24VAC -SO SENSOR OPERATED VALVE MAINTENANCE INSTRUCTIONS		
	MANUFACTURE DATE	DATE ISSUED	DRAWING NUMBER
FEBRUARY 2012	02/09/12	9940-010-003	
TO PRESENT	DATE REVISED		



PRELIMINARY STEPS:

1. Flush water supply line prior to installation. This will remove unwanted debris from the lines and prevent unwanted blockages in the safety equipment.
2. In order to comply with ANSI Z358.1, the safety equipment must be inspected periodically. An inspection tag is provided for documentation purposes.
3. All employees at risk of eye contamination should be informed and trained in the use of this and any other safety equipment. The signage provided should be posted appropriately in close proximity as required by ANSI and OSHA.
4. Position sign with clear visibility, in close proximity to safety equipment and mark mounting hole locations.
5. Select appropriate 1/4" anchors, screws and washers (supplied by others) to install signage.
6. Attach inspection tag supplied with plastic zip tie. ANSI

OPERATION INSTRUCTIONS:

Employees who work with hazardous materials should become familiar with the location and operation of the nearest emergency plumbing fixture. Emergency plumbing fixtures stations are simple to use and require hands free operation once the station is activated. Regular instruction regarding proper care and use will increase confidence that the units are accessible and function properly.

The route and area surrounding the Eye Wash should be clear and unobstructed; the sooner eyes are flushed, the less likelihood of damage. Eye Wash stations should be located in close proximity to the hazard and take no more than 10 seconds to reach. In the case of severe eye contamination the victim may require assistance to the Eye Wash station and help flushing their eyes.

Safety plumbing fixture equipment should be operated weekly for a period long enough to verify operation, clear the supply line of any sediment build-up and minimize microbial contamination due to sitting water.

1. To start the Eye Wash, swing spray nozzle assembly down horizontally over the basin or fully "ON" position. Flushing should start, popping the spray nozzle caps open.
2. Lower both eyes into flow. Both eyes should be flushed to prevent contamination from one eye from being delivered to unaffected eye. Personnel who wear contact lenses should remove them immediately prior to or during the flush to prevent the contamination from remaining against the cornea possibly causing unnecessary damage or pain.
3. Using thumb and forefingers, fully open eyelids and flush eyes thoroughly for approximately 15 minutes or until medical personnel arrive. Be prepared to let the doctor know what type of contamination has entered the eye.
4. When finished swing spray nozzle assembly up or fully "OFF" position. Flushing fluid should stop. Once flushing fluid has stopped flowing, return spray nozzle lids to the closed position to protect from airborne contaminants.

MAINTENANCE GUIDE:

Maintain and inspect in accordance with ANSI Z358.1-2009

1. Check for obvious signs of wear, broken or defective equipment. Re-paint if necessary. Replace missing or defective equipment such as broken push paddles, missing signs and inspection tags.
2. Remove strainer and washout any debris collected –replace as required.
3. Operate Eye Wash nozzles swinging the spray nozzle assembly down to place ball valve in the fully "ON" position checking for smooth operation of valve push paddle mechanism at the same time ensuring that the Eye Wash spray nozzle caps pop off immediately when actuated. If the ball valve does not operate smoothly check the actuating assembly for binding or missing parts. If the Eye Wash spray nozzle caps do not pop off immediately when actuated check for correct supply inlet pressure.
4. While in operation, inspect spray nozzles for clogs or debris correct or replace as required.
5. Swing spray nozzle assembly up to fully "OFF" position and swing back to stand by position. To prevent Eye Wash spray nozzles from becoming contaminated, always close nozzle lids after each use.



REPAIR PARTS:

NOTE:

Individual parts not available for purchase, sold in repair kits only. Parts called out for reference only.

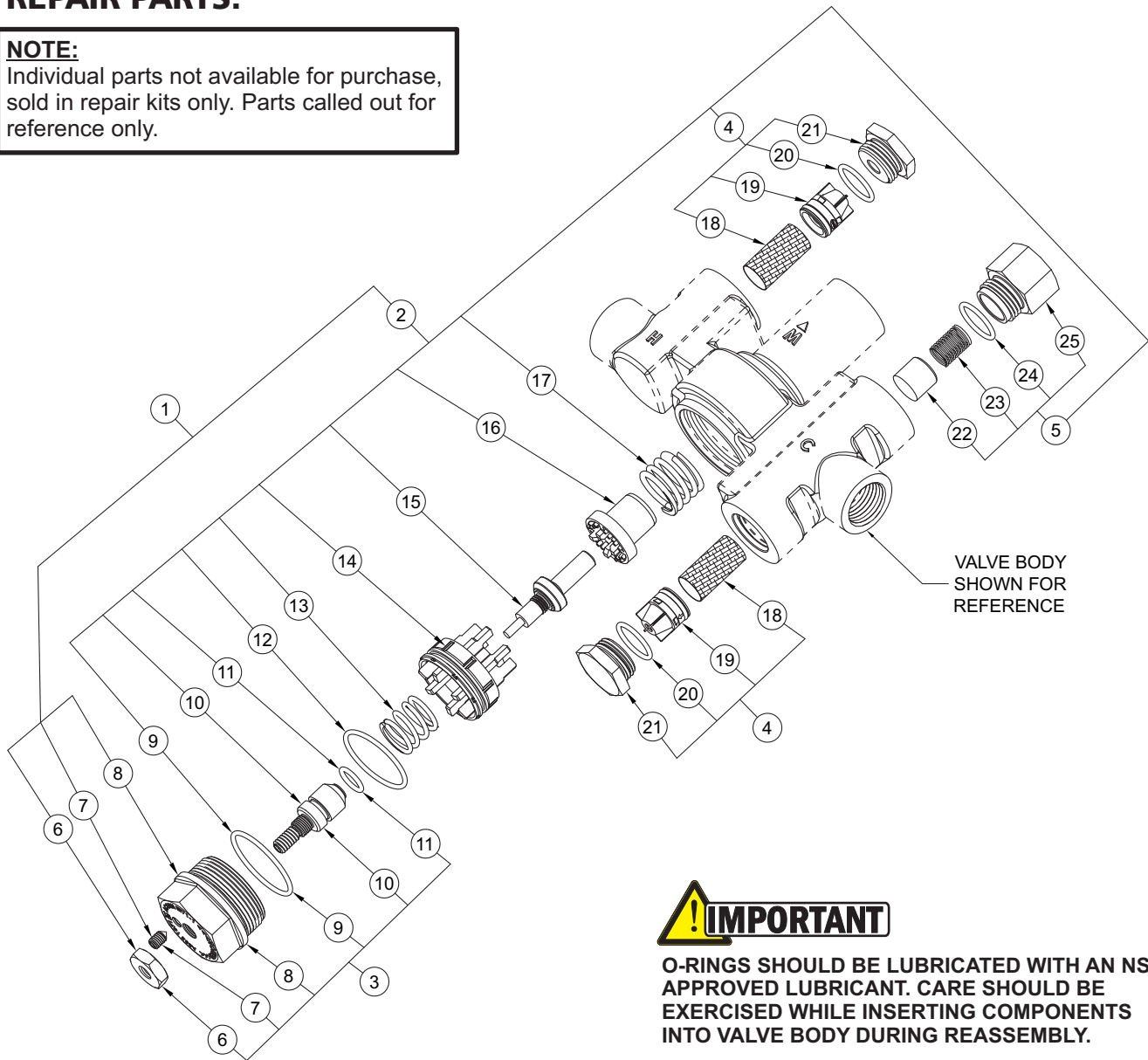

! IMPORTANT

O-RINGS SHOULD BE LUBRICATED WITH AN NSF APPROVED LUBRICANT. CARE SHOULD BE EXERCISED WHILE INSERTING COMPONENTS INTO VALVE BODY DURING REASSEMBLY.

ITEM	DESCRIPTION	ET71-1 KIT NUMBER
1	COMPLETE REBUILD KIT	7801-500-001
2	INTERNAL REPAIR KIT	7801-501-001
3	BONNET / STEM REPLACEMENT	7801-502-001
4	CHECK VALVE / STRAINER KIT	7801-503-001
5	BY-PASS REPAIR KIT	7801-504-001

ITEM	DESCRIPTION	ITEM	DESCRIPTION	ITEM	DESCRIPTION
6	ADJUSTMENT STEM LOCK NUT	13	UPPER SPRING	20	CHECK VALVE BONNET O-RING (x 2)
7	HIGH TEMPERATURE LIMIT STOP	14	SHUTTLE	21	CHECK VALVE BONNET (x 2)
8	VALVE BONNET	15	THERMOSTATIC MOTOR	22	BY-PASS POPPET
9	BONNET O-RING	16	FUNNEL	23	BY-PASS SPRING
10	ADJUSTMENT STEM	17	LOWER SPRING	24	BY-PASS BONNET O-RING
11	ADJUSTMENT STEM O-RING	18	INLET SCREEN (x 2)	25	BY-PASS BONNET
12	SHUTTLE O-RING	19	CHECK VALVE (x 2)		



ITEM #	PART NUMBER	DESCRIPTION
1	6410-208-005	SWING DOWN VALVE COVER, LH
2	7100-140-001	EYE WASH STRAINER ASSY
3	6410-208-004	SWING DOWN BRACKET ASSY, LH
4	7104-319-000	#8 HEX BUTTON HEAD SCREW
5	1932-010-000	3/8" NPT CLOSE NIPPLE
6	7104-047-001	SWING ARM VALVE ASSY
7	LABLE DISK, SWING ARM VALVE	
8	7104-207-199	RETAINING NUT
9	6410-208-002	CHROME SWING DOWN YOKE ASSY
10	7101-104-001	FACE WASH ASSEMBLY, LH

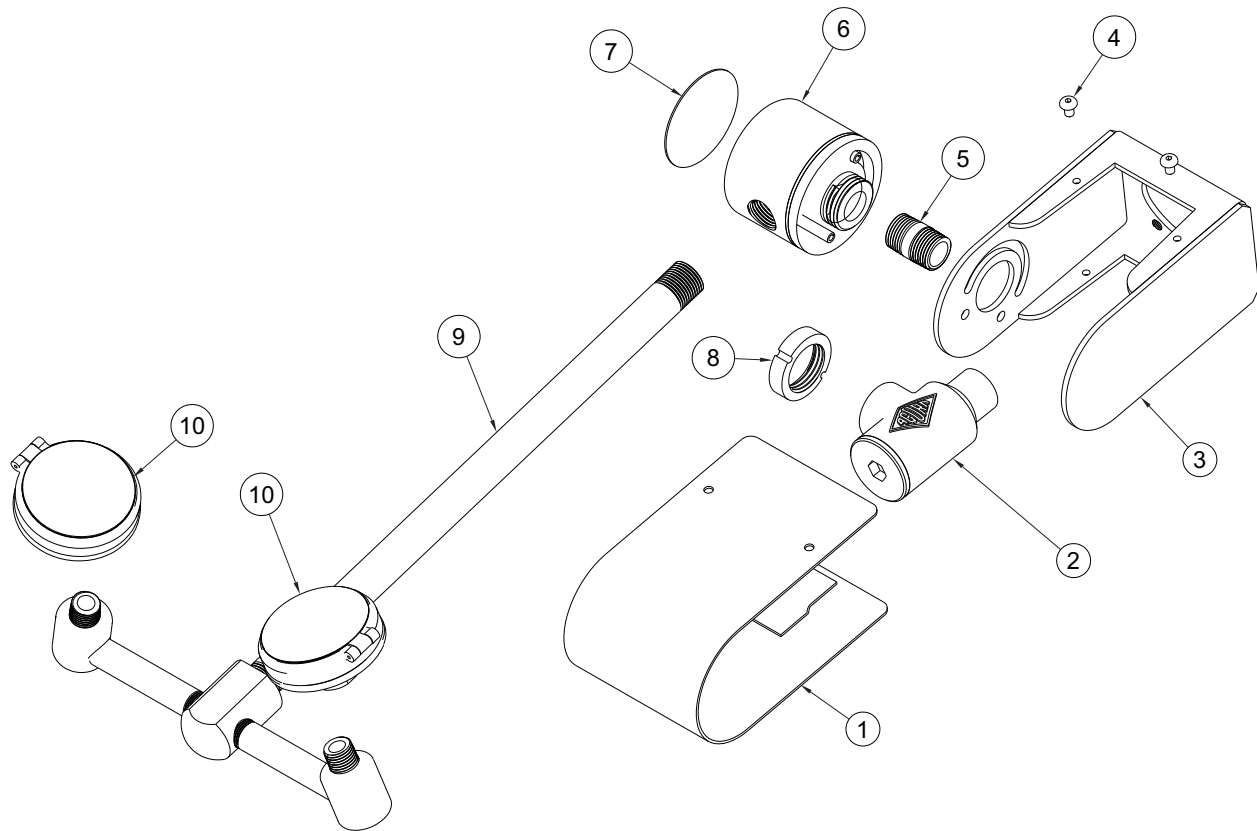



ITEM#	PART NUMBER	DESCRIPTION
1	6410-208-005	SWING DOWN VALVE COVER
2	7100-140-001	EYE WASH STRAINER ASSY
3	6410-208-003	SWING DOWN BRACKET ASSY, RH
4	7104-319-000	#8 HEX BUTTON HEAD SCREW
5	1932-010-000	3/8" NPT CLOSE NIPPLE
6	7104-047-001	SWING ARM VALVE ASSY
7	7104-045-150	LABLE DISK, SWING ARM VALVE
8	7104-207-199	RETAINING NUT
9	6410-208-002	CHROME SWING DOWN YOKE ASSY
10	7101-104-002	FACE WASH ASSEMBLY, LESS LID

