



**Whitehall
 Wash-Up Sink
 ADA Compliant
 Two Station**

Model 4172



Please visit www.whitehallmfg.com
 for most current specifications.

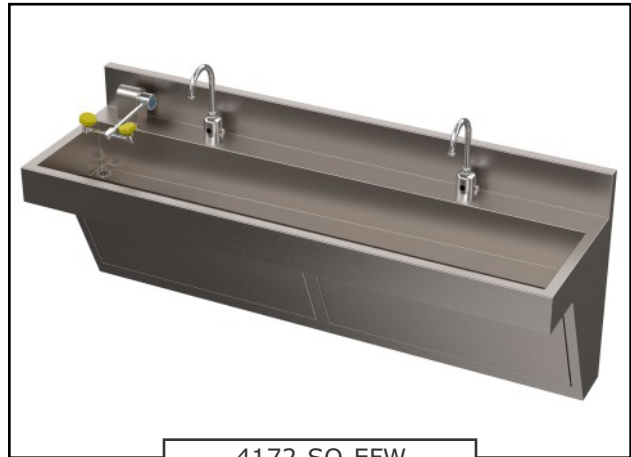

4172-SO-EFW

Fixture May Show Some Available Options

Wash-Up Sink is primarily intended for use in Healthcare institutions such as Pharmacies, Healthcare, Medical buildings, and Hospitals providing a convenient Sink to wash up.

Fixture is fabricated from 16 gage, type 304 stainless steel and is seamless welded construction with a satin finish. The Cabinet interior is sound-deadened with a fire-resistant material. The unit is designed with the capability of being installed on the wall using a Mounting Carrier.

Wash-Up Sink is provided with a Front Panel which is easily opened for access to Waste Connections, Stops and Strainers. Wash-Up Sink has a Sloping Bottom Surface to minimize splashing and a 1-1/4" OD Tailpiece with a Grid Strainer Drain and 1-1/2" O.D. P-Trap.

Optional -EFW Eye/Face Wash provides a Safety Manufacturing™ Model S0860 Series Swing Down Eye-Face Wash within Sink Trough.

Models with -EFW Option comply with USP 800, Section 5.3 Eyewash Station Requirements.

GUIDE SPECIFICATION

Provide Whitehall ADA Wash-up Sink (specify model number and option). Fixture shall be fabricated from 16 gage, type 304 stainless steel and is seamless welded construction with a satin finish. Cabinet interior shall have a sound deadening, fire-resistant material. Cabinet shall also have Removable Access Panel to allow access to Waste Connections, Stops and Strainers. Sink shall have a Sloping Bottom to minimize splashing, and a 3" Flat Strainer Drain offset left of the fixture.

Please visit www.whitehallmfg.com
 for most current specifications.



Recyclable
Product

Complies
with the
following
standards:





BASE MODEL NUMBER

- 4172 Wash-Up Sink (2 Station)

MOUNTING

- MC Mounting Carrier

WASH-UP SINK FAUCET

- SO Sensor Operated Deck Mounted Spout
- SO-BAT Sensor Operated Deck Mounted Spout - Battery Powered (batteries not included)
- 9 Without Valve (Specify Drilling)
 - H1 Single 1-3/8" Dia. Hole Centered
 - H34 Three Holes 4" Centerset (1-3/8" Dia. Holes)
 - H38 Three Holes 8" Centerset (1-3/8" Dia. Holes)

PRODUCT OPTIONS

- EFW Eye/Face Wash (Left Side Only)

NOTE: When specified, ET71-1-BVS-OTG Emergency Mixing Valve will be provided
- WHST70CP-12 ASSE 1070 Compliant Hot & Cold, Temperature Mixing Valve

NOTE: Recommend One (1) Mixing Valve Per Station.
 Valve Specs: 4.5 GPM (17 LPM) @ 45 PSI (310 kPa)
- 316 Stainless Steel In Lieu of Standard 304 STN STL

Accessories

An appropriate Chronomite Instantaneous Tankless Water Heater may be purchased separately to ship with your Wash-Up sink. Contact your sales rep for details or visit www.chronomite.com

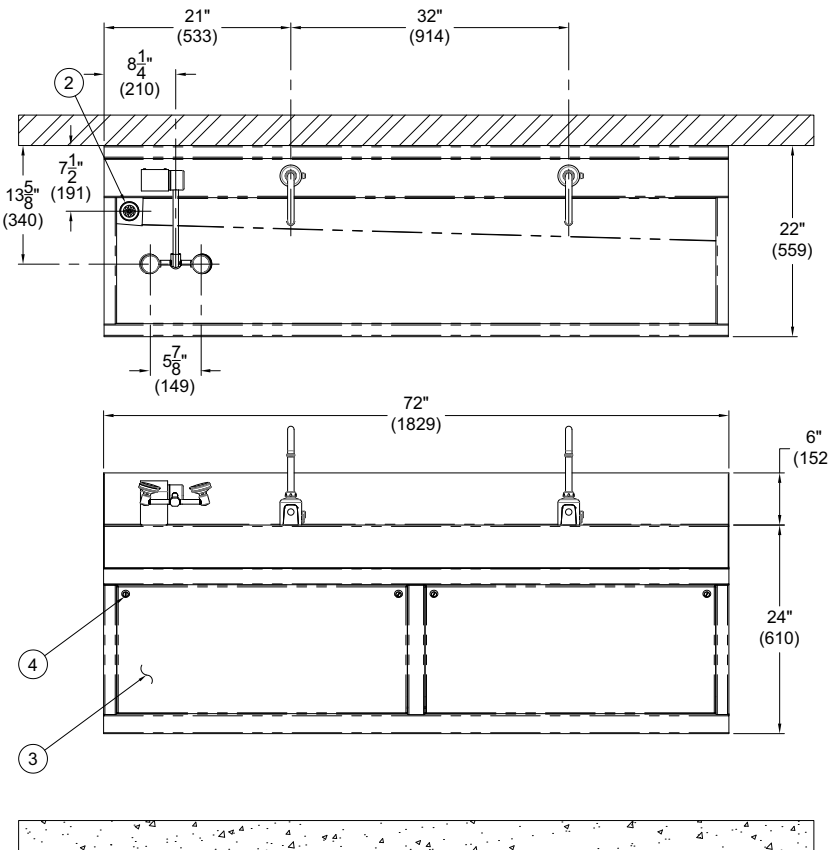

NOTES:

1. SENSOR OPERATED SPOUT
2. GRID STRAINER AND 1-1/4" TAILPIECE
3. HINGED ACCESS PANEL
4. CYLINDER LOCK
5. OPTIONAL -EFW EMERGENCY EYE/FACE WASH, SHOWN

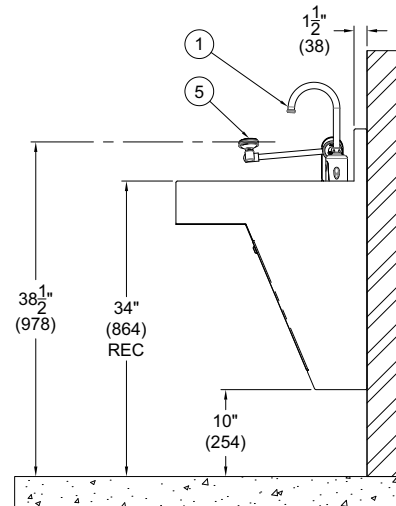

MODEL # 4172

⚠ WARNING: Cancer and Reproductive Harm - www.P65Warnings.ca.gov

SELECTION SUMMARY & APPROVAL FOR MANUFACTURING

Model Number & Options _____ Quantity _____
 Company _____ Date _____
 Contact _____ Title _____
 Approval for Manufacturing/Signature _____

All dimensions are nominal and subject to manufacturer's change without notice. Whitehall assumes no responsibility for use of void or suspended data © Whitehall Manufacturing, Member of Morris Group International. Please visit www.whitehallmfg.com for most current specifications.