

REFERENCE DRAWINGS	
INSTALLATION	DRAWING
MOUNTING CARRIER	9933-004-001

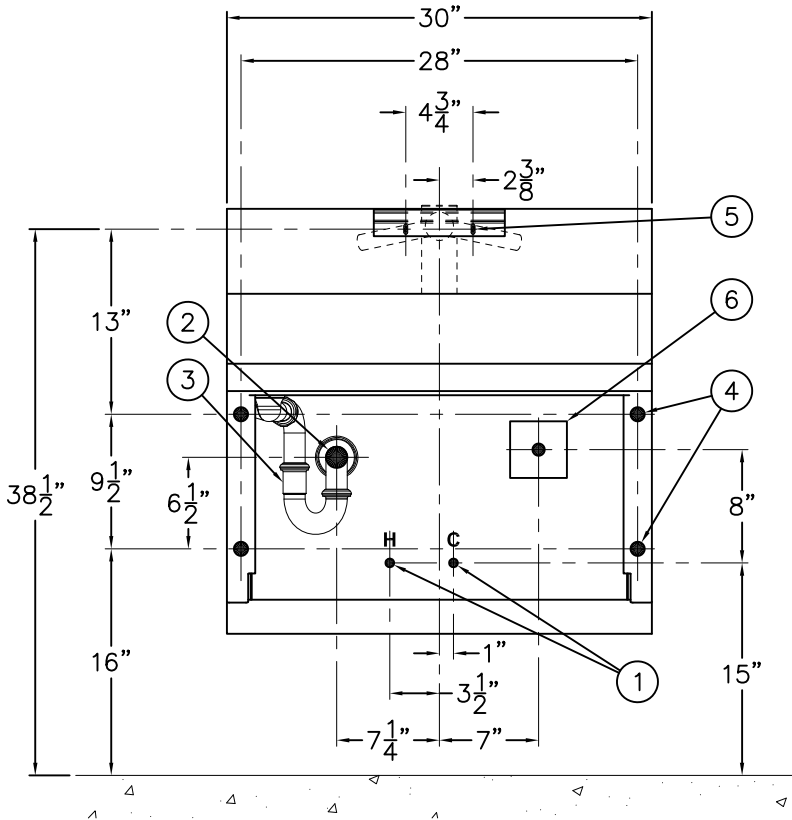

VIEW FROM FRONT OF FIXTURE

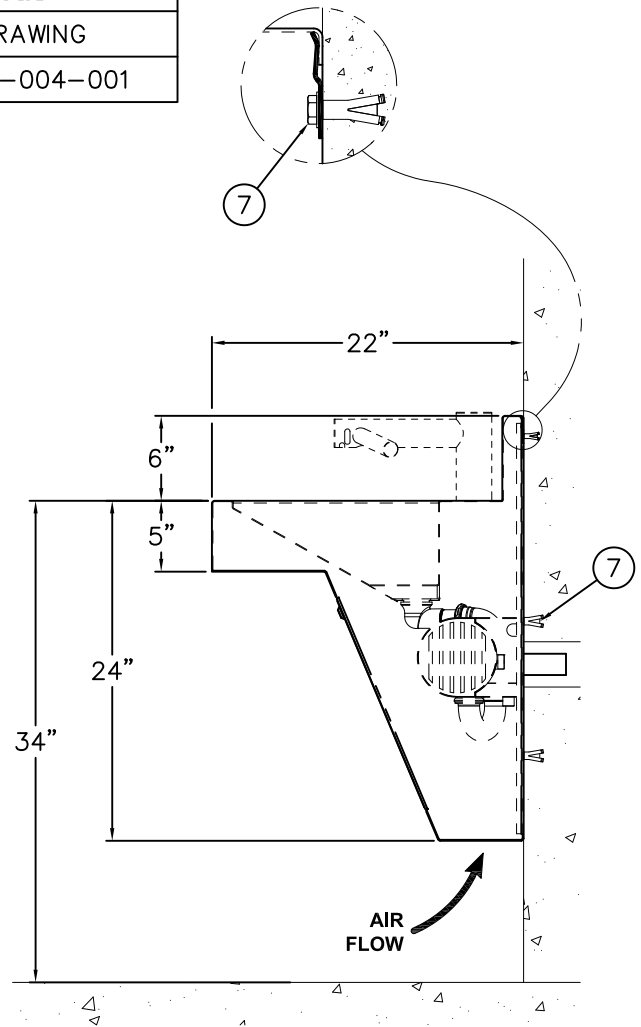

**INSTALLATION INSTRUCTIONS:**

A- ROUGH-IN FOR THE FOLLOWING:

- HOT AND COLD SUPPLIES (1) FOR 1/2" ANGLE STOPS BY OTHER.
  - WASTE OUTLET (2) FOR 1-1/2" OD P-TRAP (3) PROVIDED.
  - Ø1" MOUNTING POINTS (4) AND Ø1/4" x 3/4" S-CLIP MOUNTING SLOTS (5) FOR WALL ANCHORS AND ANCHORING HARDWARE BY OTHERS.
  - ELECTRICAL SERVICE (6).
- NOTE:** FOR WHITEHALL #4171 -SO SENSOR OPERATED FAUCET, 120VAC/60Hz, 3A CIRCUIT.  
FOR NEO-METRO #9171 OPTIONAL WDO4 REQUIRES A DEDICATED 120VAC/60Hz, 15A CIRCUIT

B- LAYOUT AND INSTALL WALL ANCHORS BY OTHERS (7) FOR MOUNTING.

C- REMOVE ACCESS DOOR, POSITION FIXTURE INTO PLACE AND SECURE TO WALL USING WASHERS AND NUTS BY OTHERS. TORQUE NUTS TO 60 FT-LBS. MAKE UP SUPPLY AND WASTE CONNECTIONS AS REQUIRED.

**WARNING:** SUPPLY LINES SHOULD BE FLUSHED OF ALL FOREIGN MATERIAL SUCH AS PIPE DOPE, CHIPS, SOLDER ETC. VALVE MUST BE DRAINED PRIOR TO BEING SUBJECTED TO FREEZING TEMPERATURES. MAXIMUM RECOMMENDED OUTLET WATER TEMPERATURE IS 105° F.

**NOTE:**

TRANSFORMER MUST BE WIRED TO A GFI PROTECTED CIRCUIT. FIXTURE MUST BE EARTH GROUNDED PER N.E.C. (NATIONAL ELECTRICAL CODE)

 <p><b>MORRIS GROUP INTL</b> P.O. BOX 3527 Industry, CA 91744 MORRIS GROUP 15125 Proctor Ave Industry, CA 91746 INTERNATIONAL (626) 336-4561 FAX (626) 961-2200</p>	<p>TITLE <b>INSTALLATION INSTRUCTIONS FOR WHITEHALL * 4171 &amp; NEO-METRO * 9171</b></p>		
	<p>MANUFACTURE DATE</p> <p><b>MARCH 2019</b></p> <p><b>PRESENT</b></p>	<p>DATE ISSUED</p> <p><b>03/13/19</b></p> <p>DATE REVISED</p> <p><b>04/01/2020 A</b></p>	<p>DRAWING NUMBER</p> <p><b>9933-001-001</b></p>

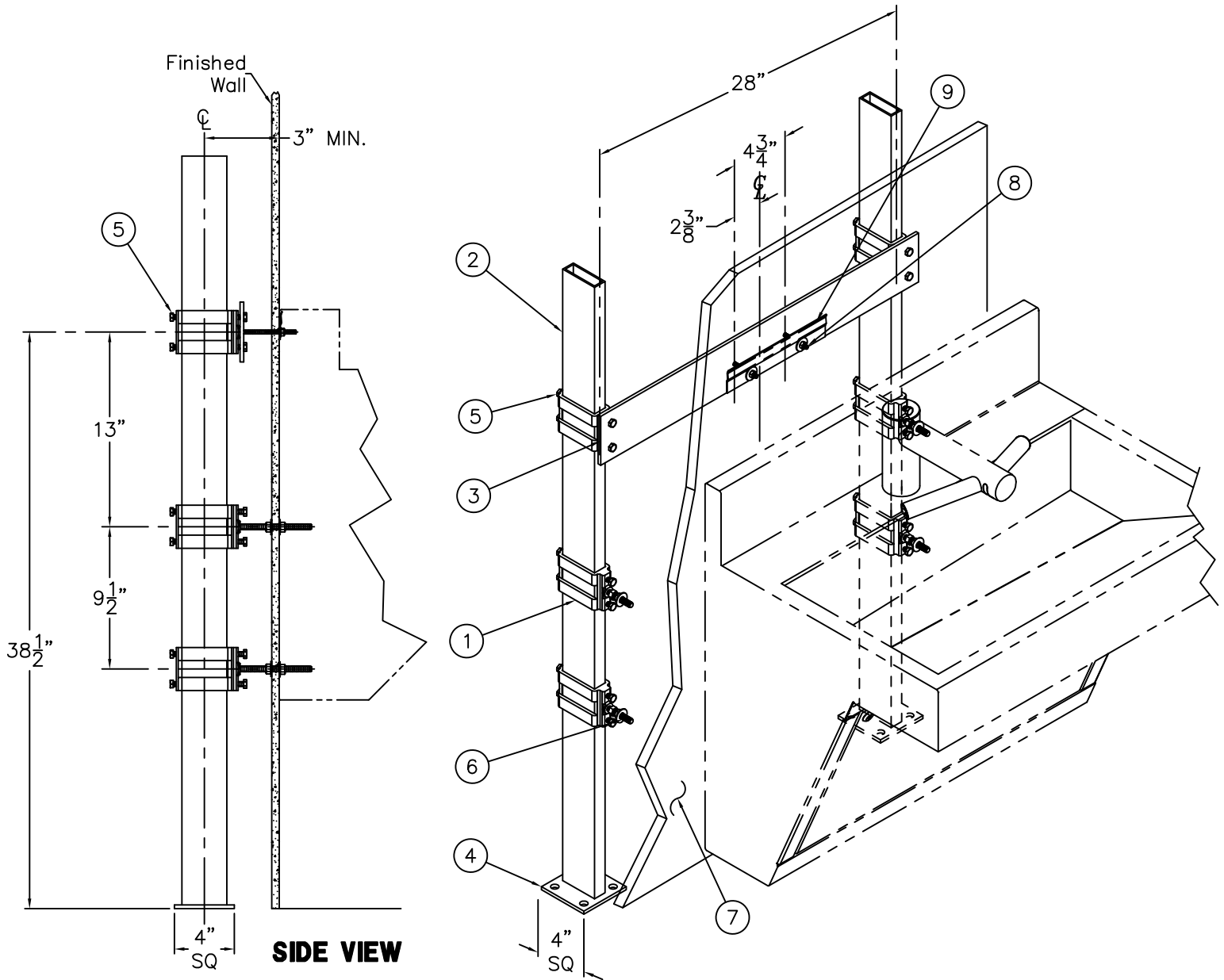

**INSTALLATION INSTRUCTIONS:**

- A- PRIOR TO INSTALLING FINISH WALL COVERING (7) ASSEMBLE -MC MOUNTING CARRIER.
- B- PLACE COLLARS (1) ON STANCHIONS (2) AND INSTALL HORIZONTAL SUPPORTS (3) ONTO STANCHIONS (2).
- C- ANCHOR SUPPORT BASES (4) TO A RIGID FLOOR OR OTHER RIGID SUBSTRUCTURE WITH 9/16" DIA. CAP NUTS & WASHERS (4) BY OTHERS.
- D- ADJUST COLLARS (1) TO PROPER HEIGHT AND TIGHTEN SET SCREWS (5).
- E- INSTALL WALL COVERING (7) ALLOWING ACCESS TO 3/8" MOUNTING STUDS (6) AND 1/4" STUDS (8) FOR "S" CLIP MOUNTING.
- F- INSTALL "S" CLIP MOUNTING BRACKET(S) (9) ON FINISHED FACE OF WALL (7).
- G- COMPLETE ANY NECESSARY ROUGH-IN CONNECTIONS (NOT SHOWN) FOR SUPPLY AND WASTE PIPING. COMPLETE INSTALLATION OF FINISHED WALL AND MOUNT SCRUB SINK TO "S" CLIP(S) AND PROTRUDING STUDS.

<p><b>MORRIS GROUP INTL</b> P.O. BOX 3527 Industry, CA 91744 MORRIS GROUP 15125 Proctor Ave Industry, CA 91746 INTERNATIONAL (626) 336-4561 FAX (626) 961-2200</p>	<p>TITLE <b>-MC MOUNTING CARRIER INSTALLATION DETAIL: 4171 &amp; 9171</b></p>	
	<p>MANUFACTURE DATE <b>MARCH 2019</b> <b>TO PRESENT</b></p>	<p>DATE ISSUED <b>03/13/19</b></p> <p>DATE REVISED</p>